

M-iClean U

Glass, utensil and dishwasher

Installation instructions

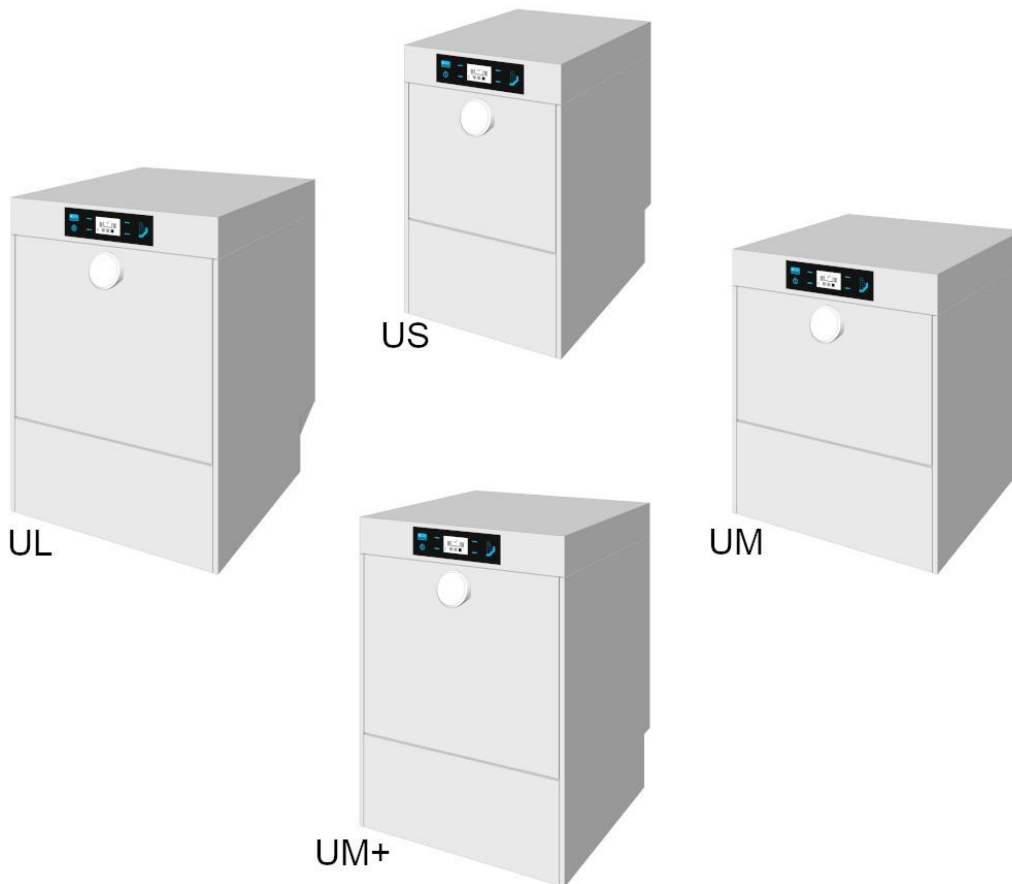

For the types in the series: M007DWUC10M*-.****



Read before assembling the machine!



Contents

1	NOTICE REGARDING INSTALLATION INSTRUCTIONS	3
1.1	Product identification	3
1.2	Presentation conventions	3
1.2.1	<i>Warnings</i>	3
1.2.2	<i>Notices on use</i>	3
1.2.3	<i>Award elements</i>	3
1.2.4	<i>Safety symbols in the instructions</i>	3
2	SAFETY	4
2.1	Safety information	4
3	TRANSPORT	5
3.1	Checking the condition at delivery	5
4	TECHNICAL DATA	6
5	DIMENSIONAL DRAWINGS AND CONNECTION DIMENSIONS	7
5.1	Recess dimensions	7
6	INSTALLATION	9
6.1	Requirements to the electrical connection	9
6.2	Requirements for the fresh water connection	10
6.3	Requirements for the waste water connection	12
7	ASSEMBLY	12
7.1	Connecting the GiO MODULE	13
7.1.1	<i>Connection situation: Machine with GiO MODULE with heat recovery</i>	14
7.1.2	<i>Connection situation: Machine with GiO MODULE without heat recovery</i>	15
7.1.3	<i>Connecting the GiO MODULE in the rear panel</i>	15
7.1.4	<i>Separately positioned GiO MODULE</i>	18
7.1.5	<i>Connecting the GiO MODULE electrically</i>	20
7.2	Installing the base cabinet	20
7.3	Installing the frame, roller plinth or slide rails	24
7.4	Connecting the dosing pipes to the machine	25
7.4.1	<i>Connecting suction lances without empty-tank detection</i>	25
7.4.2	<i>Connecting suction lances for empty level indication</i>	27
7.5	Connecting the fresh water pump to the machine	28
7.6	Connecting the waste-water line	29
7.7	Routing cables	29
7.8	Aligning the machine and pushing it into niche	30
7.9	Making connections on site	31
7.9.1	<i>Connect fresh water line</i>	31
7.9.2	<i>Connect waste-water line</i>	31
7.9.3	<i>Connect electrically</i>	31
8	COMMISSIONING	31
9	INDEX	32

1 Notice regarding installation instructions

1.1 Product identification

This document applies to the machine types:

M-iClean US :	M007DWUC10M*-10
M-iClean UM :	M007DWUC10M*-20
M-iClean UM+ :	M007DWUC10M*-30
M-iClean UL :	M007DWUC10M*-40

1.2 Presentation conventions

1.2.1 Warnings

 **DANGER** – indicates an imminently hazardous situation which, if not avoided, will result in serious injury or death.

 **WARNING** – indicates a potentially hazardous situation which, if not avoided, could result in serious injury or death.

 **CAUTION** – indicates a possible hazardous situation which, if not avoided, could result in minor or moderate injury or damage to property.

1.2.2 Notices on use



Note – indicates useful and important information about the product or its use.

1.2.3 Award elements





Description of the markup elements used in this document:

- A bullet point designates an action step.

1. Successive action steps.

(1) Position numbers shown in parentheses in the text refer to position numbers in illustrations. The text associated with the illustration is always below or beside the respective illustration.

1.2.4 Safety symbols in the instructions

	Read document		Potential equalisation connection
	Caution		Manufacturer

2 Safety

2.1 Safety information

Authorisation for assembly/installation and commissioning

- Assembly may only be performed by a specialist company. Installation may only be performed by electricians/plumbers.
- Commissioning may only be performed by a service technician authorised by MEIKO.

Installation site

- Only furniture that is resistant to condensation should be used in the vicinity of the dishwashing machine.
- Observe the installation conditions (see page 9).

Electrical safety

- The electrical safety of this appliance is only ensured if it is connected to a properly installed protective earth conductor system. It is very important to verify this fundamental safety feature. If in doubt, have the local wiring checked by an electrician. The manufacturer cannot be held liable for damage caused due to the protective earth conductor being missing or disconnected (e.g. electric shock).
- Modifications to electrical systems during installation may only be carried out by a qualified electrician.

Dosing agent

- Take care when handling dosing agents (water softeners/rinsing aids and detergents). They are corrosive substances. Observe the applicable safety regulations! Use safety eyewear and protective gloves. Observe the manufacturer's safety instructions and safety data sheets when handling dosing agents.
- Do not inhale vapours from dosing agents.

General

- Only use the dishwashing machine in its original condition without independent changes and in a technically perfect condition.
- Do not sit or stand on the opened wash chamber door. This could damage the appliance and cause injury.
- Do not place any objects on the dishwashing machine.

3 Transport

⚠ WARNING – danger of injury due to machine tipping

- Only qualified personnel may carry out transport works.
- Please note safety notices on the packaging.
- Always transport the machine on a wooden frame only.
- Wear protective gloves and safety shoes.

The packaging is specifically designed to allow the appliances to be moved safely and securely using a pallet jack or a sack truck. For safe transport, the dishwashing machine is supported by a special square-timber frame.

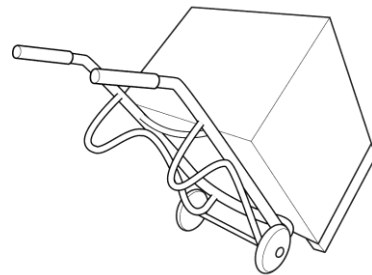
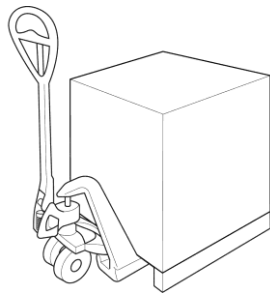

- Execute transport carefully.
- Open packaging using a suitable tool.
- Unpack the dishwashing machine only after transport is completed.

3.1 Checking the condition at delivery

- Check that the delivery is complete immediately after receiving it by comparing it with MEIKO's order confirmation and/or the delivery note.
- If applicable, submit a claim for any missing parts immediately to the freight forwarder and notify MEIKO.
- Check the machine for transportation damage.



Note

If there is any suspicion of transportation damage, the shipping company and MEIKO must be informed immediately in writing. Photograph any damaged parts and send the pictures to MEIKO.

4 Technical data

Ambient conditions	
Operating temperature	5°C ... 40°C
Relative humidity	< 95%
Storage temperature	5°C ... 40°C
Maximum height of the installation site above sea level	2000 m

Net weights			
Version	Machine	Machine with GiO in the plinth	Machine with GiO separately
M-iClean US	56 kg	63 kg	80 kg
M-iClean UM	63 kg	82 kg	87 kg
M-iClean UM+	74 kg	93 kg	98 kg
M-iClean UL	77 kg	96 kg	101 kg

Noise emission	
Emission sound pressure level at the workplace	≤70 dB (A)

Technical data of the radio module	
Frequency band	2412–2484 MHz
WLAN standard	IEEE 802.11 b/g/n
Bluetooth version	4.2
Max. transmission power	20 dBm

Further data should be taken from the MEIKO dimension sheet.

5 Dimensional drawings and connection dimensions

5.1 Recess dimensions

When installing the dishwasher in a counter, recess dimensions must be observed. The dishwasher does not need to be fixed in the counter. Furniture in the vicinity of the dishwasher must be suitable for commercial use and resistant to steam.

Dishwasher without plinth

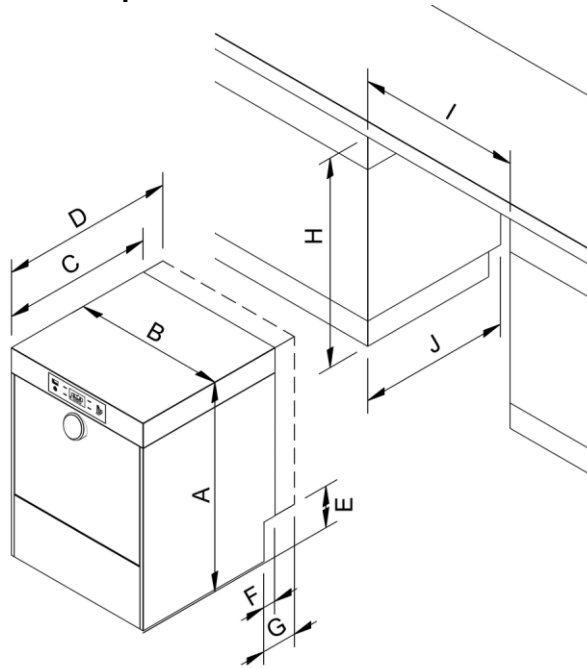

The dishwasher can also be set up without feet, in which case alignment is no longer possible.

Height of the machine without feet in mm:

US/ US GiO rear panel/ UM/ UM (GiO rear panel)	UM+/ UM+(GiO rear panel)/ UL
700 ⁺⁵	820 ⁺⁵

M-iClean U / M-iClean U Type M2 (dimensions in mm)							
	US	US (GiO rear panel)	UM	UM (GiO rear panel)	UM+	UM+ (GiO rear panel)	UL
A	710–735	710–735	710–735	710–735	830–855	830–855	830–855
B	460	460	600	600	600	600	600
C	600	–	600	–	600	–	680
D	–	690	–	690	–	690	–
E	155	155	155	155	155	155	155
F	50	–	50	–	50	–	130
G	–	140	–	140	–	140	–
H	715–735	715–735	715–735	715–735	835–855	835–855	835–855
I	470–480	470–480	610–620	610–620	610–620	610–620	610–620
J	605	695	605	695	605	695	685

Dishwasher with plinth 120 mm or 150 mm

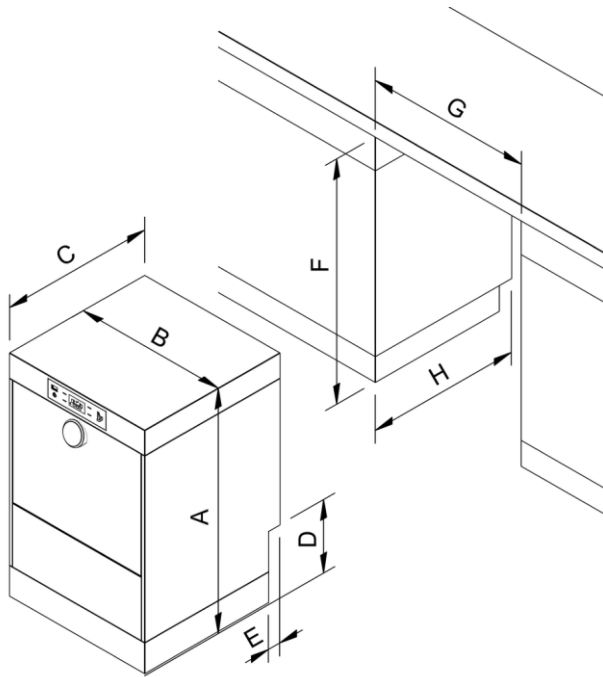

The dishwasher can also be set up without feet, in which case alignment is no longer possible.

Height of the machine without feet in mm:

US 120/ UM 120	US 150/ UM 150	UM+ 120/ UL 120	UM+ 150/ UL 150
820 ⁺⁵	850 ⁺⁵	940 ⁺⁵	970 ⁺⁵

M-iClean U / M-iClean U Type M2 (dimensions in mm)								
	US 120	US 150	UM 120	UM 150	UM+ 120	UM+ 150	UL 120	UL 150
A	830–855	860–885	830–855	860–885	950–975	980–1005	950–975	980–1005
B	460		600		600		600	
C	600		600		600		680	
D	275	305	275	305	275	305	275	305
E	50		50		50		130	
F	835–855	865–885	835–855	865–885	955–975	985–1005	955–975	985–1005
G	470–480		610–620		610–620		610–620	
H	605		605		605		685	

6 Installation

6.1 Requirements to the electrical connection

Electrical connection must be carried out in accordance with the locally applicable regulations (e.g. HD 60364-1/IEC 60364-1/VDE 0100-100) so the machine can be connected to the mains supply in accordance with the installer's regulations. However, national installer's regulations may differ. The machine and accessory appliances are intended for permanent connection to the on-site power supply and the on-site protective equipotential bonding and have been tested accordingly before being brought to market.

Fuse protection

- Set up the machine according to the local conditions and according to the rated current (see rating plate) as a separately fused circuit (final circuit). Take note of the available connection variants.

Main switch/mains connection cable

- Install a main switch with all-pole disconnection from the mains in accordance with the installer's regulations in the permanently installed on-site installation.
- The main switch must be easily accessible for the operating personnel.
- The contact opening width must correspond to overvoltage category III in each pole.
- Mains power cables, unless part of the standard product scope of supply, must be oil-resistant, sheathed, flexible cables no lighter than a normal polychloroprene-sheathed cable (or other equivalent synthetic elastomer) with the marking 60245 IEC 57.
- Mains connection cables may only be replaced by persons trained by MEIKO.

Electrical safety

- The electrical safety of this machine is only ensured if it is connected to a properly installed protective conductor system. It is very important to verify this fundamental safety feature. If in doubt, have the building wiring checked by an electrician.
- Carry out the protective measures as well as the connection of the equipotential bonding in accordance with the regulations of the local power supply companies as well as the locally applicable regulations.
- As an alternative to equipotential bonding, the operator can, acting on its own responsibility, use a mains-side residual current device (RCM or RCD) for personal protection. A type "B" (30 mA) is required due to the built-in frequency converter.

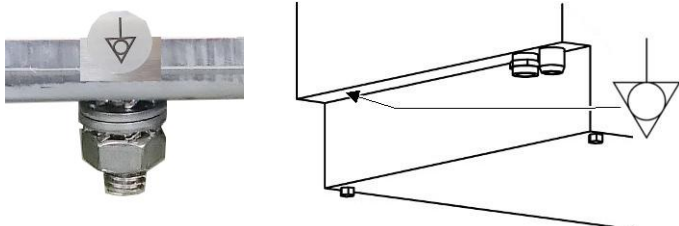
Electrical connection	
Voltage	See rating plate
Total connected load	
Fuse protection	
Equipotential bonding	 <p>The screw for the equipotential bonding is located on the back of the machine near the media connections.</p>
Residual current device*	FI type F/type B/type B+
Special national conditions	<p>USA/Canada: The dishwashing machine must be installed in accordance with local regulations. In the absence of any such regulations, install the machine in accordance with the applicable requirements in the National Electrical Code, NFPA 70, Canadian Electrical Code (CEC), Part 1, CSA C22.1 and the Standard for Ventilation Control and Fire Protection of Commercial Cooking Operations, NFPA 96.</p> <p>Australia/New Zealand: Carry out all work in accordance with AS/NZS 3000!</p>

6.2 Requirements for the fresh water connection

- From a biological perspective, the fresh water must be of drinking water quality. This also applies to treated water.
- Fresh water connections must comply with the locally applicable regulations (e.g. DIN EN 806, DIN EN 1717). Install a shut-off valve locally in each fresh water supply line; the device must be easily accessible for the operating personnel. This dishwashing machine is installed as a fully functional unit and only needs to be connected to the local power and water supply.
- Only connect the dishwashing machine using suitable hoses and seals. Hoses may only be used if in an intact condition!
- When replacing an old machine with a new one, make sure that the existing feed hose is exchanged for the new feed hose supplied with the machine.
- The hoses have a 3/4 inch thread for connecting to the on-site shut-off valves.

Fresh water connection	
Air gap	Type AB according to EN 1717 or EN 61770 Pressure booster pump after air gap
Equipment	Solenoid valve/leakage detector switch
Minimum flow pressure	60 kPa/0.6 bar upstream of the solenoid valve
With GiO MODULE	100 kPa/1 bar
Maximum pressure	500 kPa/5.0 bar (1,000 kPa in DK, SV, NO, FI)
Max. feed water temperature	60°C
With GiO MODULE	35°C
With ComfortAir (heat recovery system)	20°C
Special national conditions	In the case of SVGW (Switzerland) and other countries, a type EA safety device is also required upstream of the connection hose. Higher maximum pressure in Denmark, Sweden, Norway, Finland (see above) For Australia and New Zealand only: All work carried out must be in accordance with AS/NZS 3500.1!

Fresh water limit values when operating a reverse osmosis module	
Designation	Value
Conductivity	70 – 1,000 µS/cm
Water hardness	0 – 28 °dH
Feed water temperature	Min. 1°C to max. 35°C (cold water connection)
Minimum flow pressure	100 kPa (1 bar)
Maximum pressure	500 kPa (5 bar)
Free from particles	> 10 µm
Iron	< 0.1 mg/l
Manganese	< 0.04 mg/l
Chlorine (free chlorine)	< 0.1 mg/l (standard membrane)
Chlorine (free chlorine)	≥ 0.1 to ≤ 2.0 mg/l (more chlorine resistant membrane)
Potassium permanganate	< 10 mg/l
Silicic acid	< 10 mg/l

6.3 Requirements for the waste water connection

- Waste water connections must comply with DIN EN 1256 and the locally applicable regulations.
- Depending on the intended use of the dishwashing machine, a grease trap may be included, based on the general/location-specific regulations.

Waste water connection		
Drain pump present?	Yes	
Connecting hose extending from the machine	1.6 m	
Special national conditions	Australia: The drain hose must be connected so that it is waterproof with a drain fitting in accordance with AS 1589 AS 2887 and a sanitary waste water pipe or sanitary waste water fitting in accordance with AS/NZS 1260	
Maximum drain height above finished floor	M-iClean US/UM	M-iClean UM+/UL
Without GiO MODULE	700 mm	
With GiO MODULE on real panel and mounted separately	420 mm	540 mm
With GiO MODULE integrated in plinth (120 mm)	540 mm	660 mm
With GiO MODULE integrated in plinth (150 mm)	570 mm	690 mm

7 Assembly

When installed in a niche that is not level with the floor and/or on a pull-out system provided by the customer, the load-bearing capacity of the niche floor and/or pull-out system must be matched to the weight of the machine.

Secure the machine on a niche that is not level with the floor to prevent it from being pulled out unintentionally.

Secure the machine on a pull-out system in such a way that the machine cannot tip over or slide down when the pull-out system is extended.

7.1 Connecting the GiO MODULE



Note

Only applies to machines from M007DWUCM2-**!

Preparations must still be made for the GiO MODULE in rear panel or GiO MODULE mounted separately variants. No preparations are necessary for the GiO MODULE in the plinth.

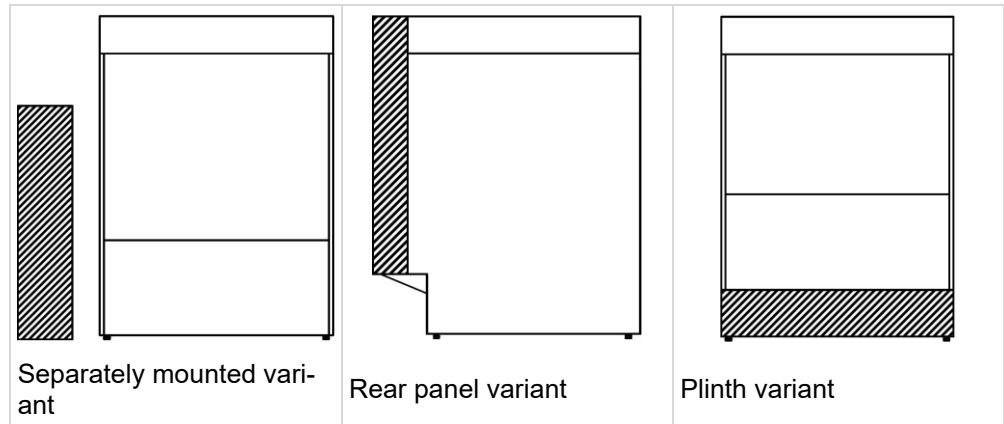

With the "GiO MODULE rear panel" variant, the hose from the externally mounted pre-filter must still be connected. With the "GiO MODULE positioned separately" variant, the lines for permeate, concentrate and permeate recirculation must also be connected in the machine.



Note

As of a water hardness of 18 °dH, please use the enclosed blue throttle (1).

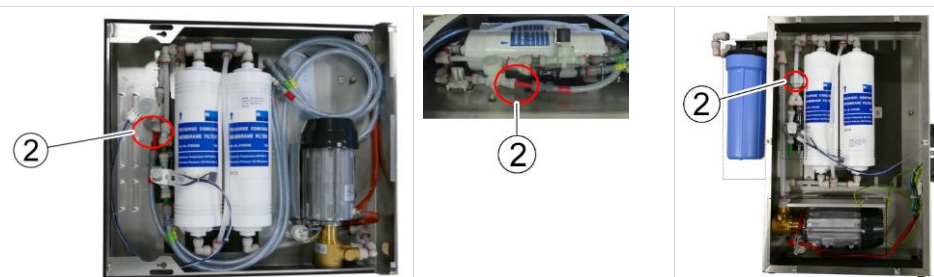
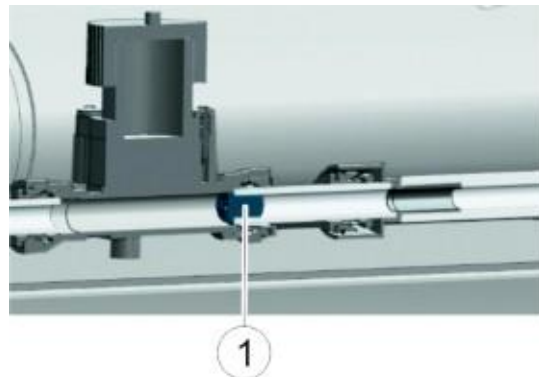

The throttle (1) is located near the dirt trap (2) in all three variants of the GiO MODULE.

Colour coding of the clear fabric hoses



- Red: Concentrate line
- Yellow/orange: Permeate recirculation line
- Green: Permeate line

7.1.1 Connection situation: Machine with GiO MODULE with heat recovery

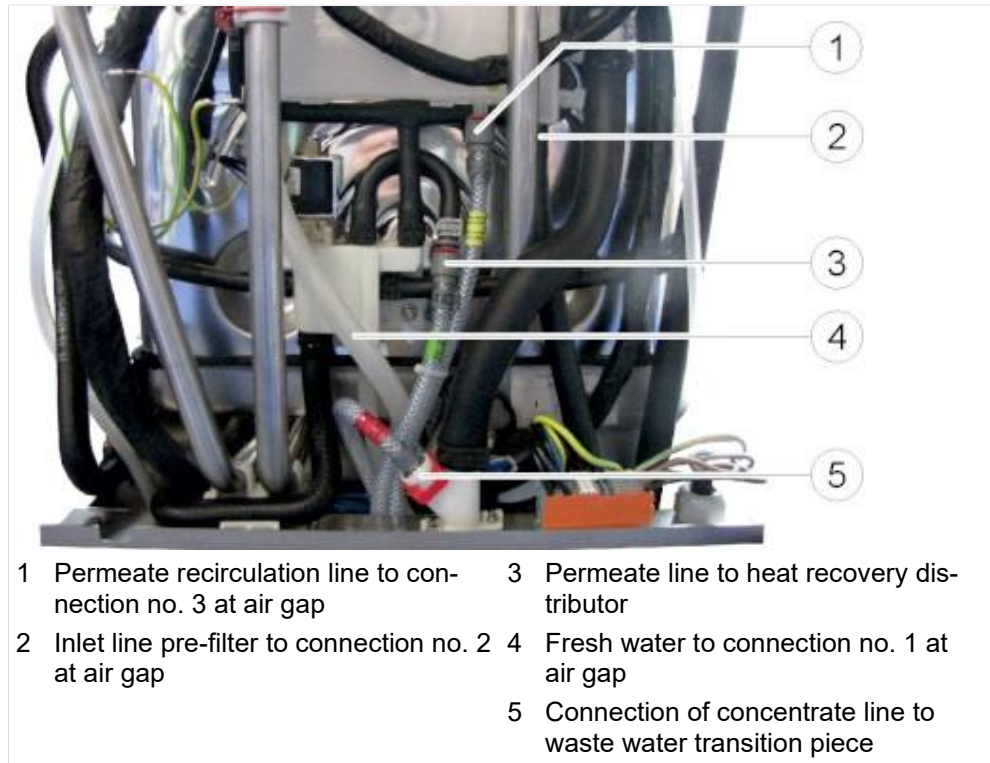

- | | |
|--|--|
| 1 Permeate recirculation line to connection no. 3 at air gap | 3 Permeate line to heat recovery distributor |
| 2 Inlet line pre-filter to connection no. 2 at air gap | 4 Fresh water to connection no. 1 at air gap |
| | 5 Connection of concentrate line to waste water transition piece |

7.1.2 Connection situation: Machine with GiO MODULE without heat recovery

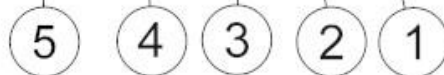

- | | | | |
|---|--|---|--|
| 1 | Inlet line pre-filter to connection no. 2 at air gap | 3 | Permeate recirculation line to connection no. 3 at air gap |
| 2 | Concentrate line to waste water transition piece | 4 | Permeate line to distribution pipe (boiler) |
| 5 | Fresh water to connection no. 1 at air gap | | |

7.1.3 Connecting the GiO MODULE in the rear panel

Connect the pre-filter to the air gap

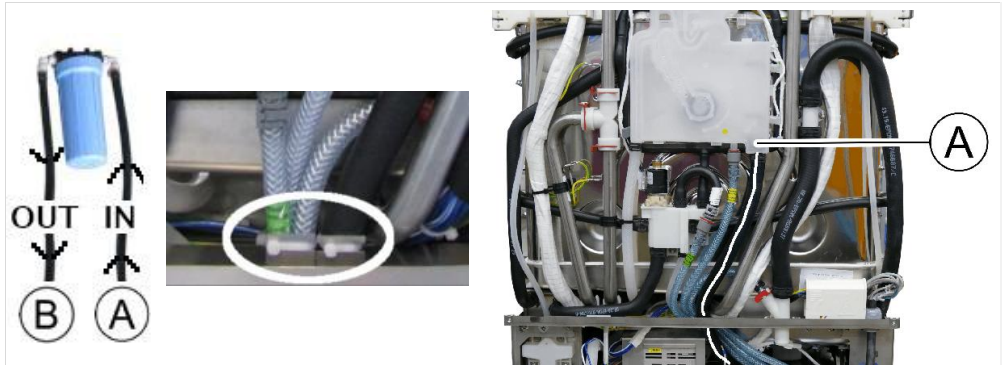

The pre-filter can be fixed to the wall max. 1.5 m from the GiO MODULE. Fasten the pre-filter at least 120 mm below the upper edge of the machine, no higher!

1. To connect the hoses, remove the rear panel module.
2. **For M-iClean UM, UM+ and UL:** Guide the hose into the machine at the inlet (A) of the pre-filter (IN) from below through the existing opening in the crossarm together **with the fabric hoses** and connect it to the right connection no. 2 of the air gap in the machine.
3. Secure with cable ties for strain relief.



For M-iClean US: Guide the hose directly into the machine through the metal sheeting and connect it to the air gap.

Connecting the pre-filter in the module for M-iClean UM, UM+

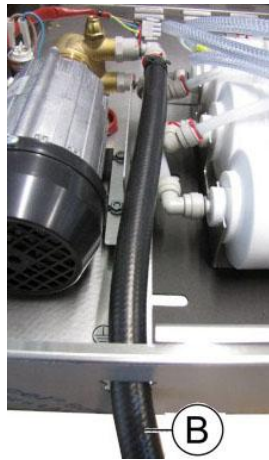

1. Guide the hose into the GiO MODULE from the outlet (B) of the pre-filter (**OUT**) from below.
2. Plug the hose into the connection on the pump housing and secure with a cir-clip.

Connecting the pre-filter in the module for M-iClean US



1. Remove the bend in the hose from the outlet (B) of the pre-filter (**OUT**).



2. Guide this hose into the GiO MOD-
ULE from below.

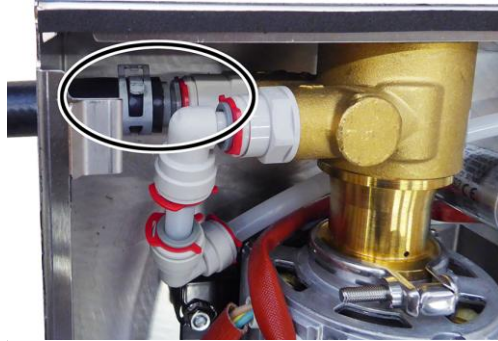

3. Plug the hose into the air gap on the pump housing and secure with a circlip.

7.1.4 Separately positioned GiO MODULE

Connecting the hoses to the GiO MODULE



With the separate GiO MODULE, connect the hoses for permeate, permeate recirculation, concentrate outlet and the feed hose to the pre-filter.



1. Pass the transparent fabric hoses (permeate, permeate recirculation, concentrate) through the lateral opening in the casing.



2. Connect the permeate recirculation line (1), permeate line (2) and concentrate line (3) to the connections according to the colour coding and secure with circlips.

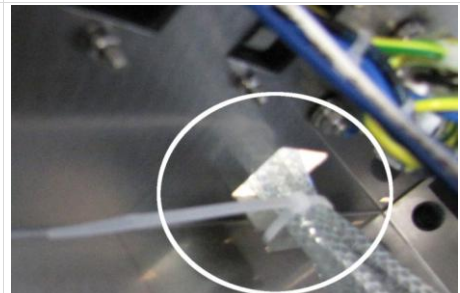

3. Secure the hoses to the casing with cable ties (strain relief).



4. Pass the feed hose to the pre-filter through the lateral openings in the casing.



5. Fasten the hose with a spring band clamp and connect the push-in elbow.



6. Insert circlips.

M-iClean UM, UM+, UL



1. Guide all hoses through the opening in the crossarm as shown and connect to the air gap as appropriate to the connection situation, see page 14.
2. Then fasten to the tabs with cable ties (strain relief).

M-iClean US



1. Guide the transparent fabric hoses through the opening in the crossarm and connect to the air gap as appropriate to the connection situation, see page 14. Then fasten to the tabs with cable ties (strain relief).

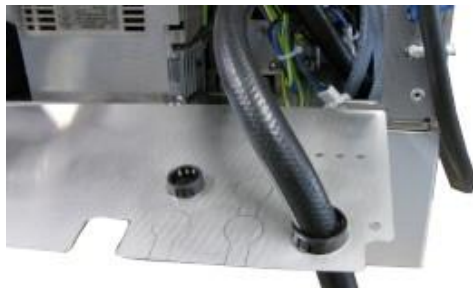

2. Guide the black hose directly into the machine through the metal sheeting to the inlet (A) of the pre-filter (IN) (separate and rear panel variant), connect to connection no. 2 (marking on the air gap) and secure with a spring band clamp.

7.1.5 Connecting the GiO MODULE electrically

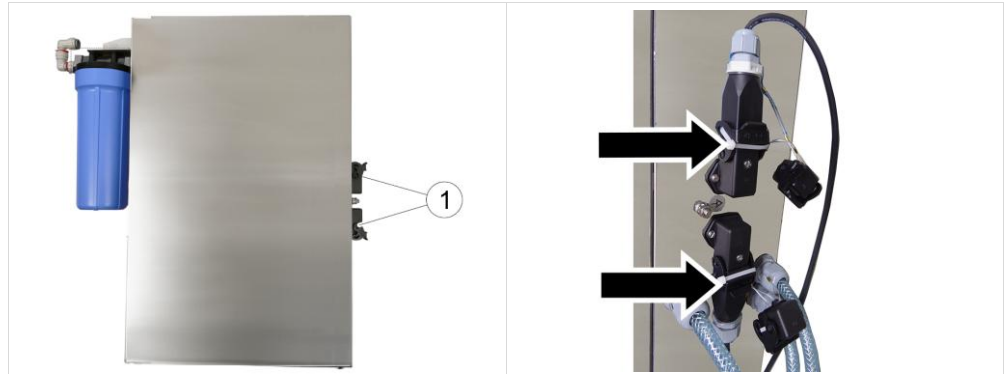

1. Insert the two plugs of the machine connection cable into the sockets provided (1), lock and secure with cable ties.
2. Connect the equipotential bonding. The screw for equipotential bonding is located between the two sockets.

7.2 Installing the base cabinet

The base cabinet provides a raised position for the machine and additional storage space.

Installing the base cabinet for machines without a GiO plinth

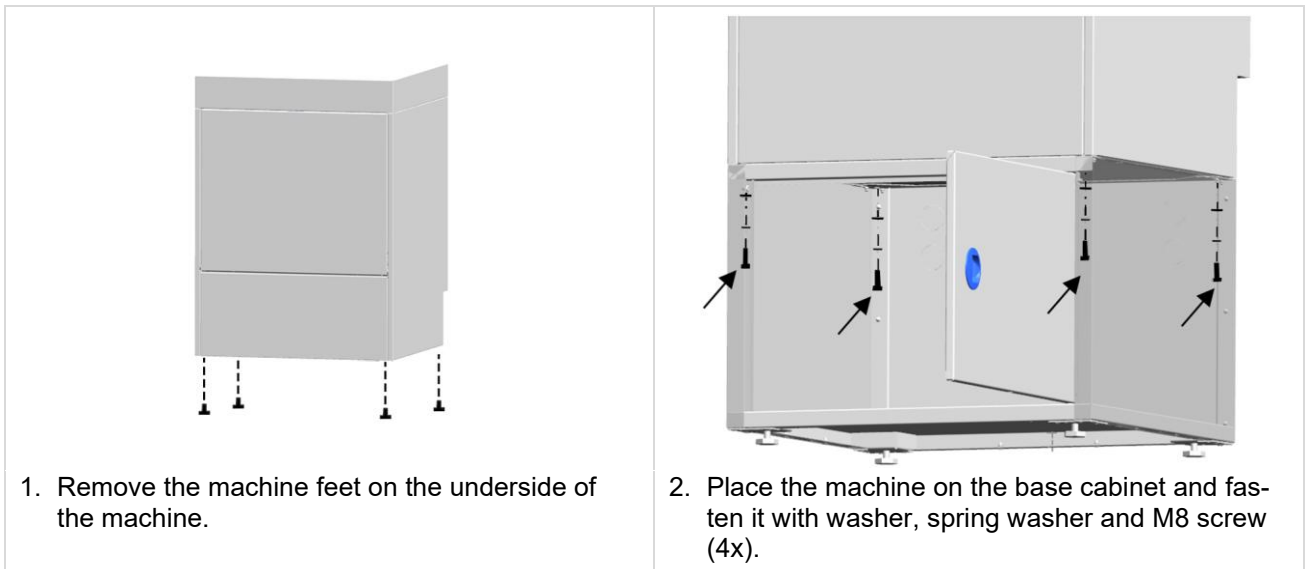

1. Remove the machine feet on the underside of the machine.
2. Place the machine on the base cabinet and fasten it with washer, spring washer and M8 screw (4x).

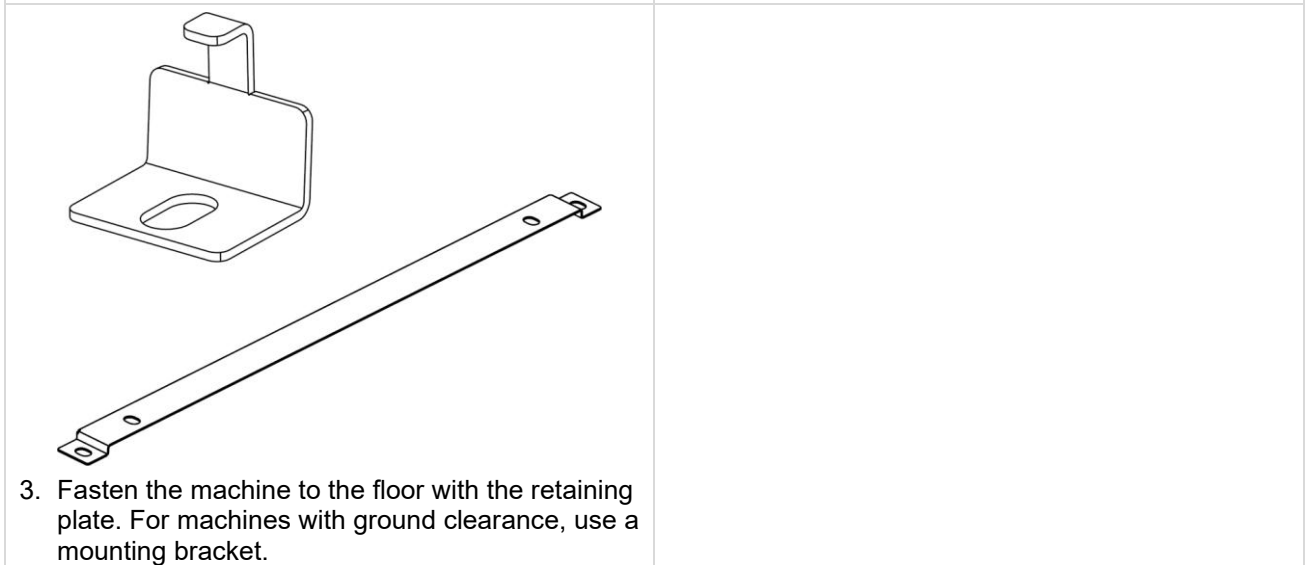

3. Fasten the machine to the floor with the retaining plate. For machines with ground clearance, use a mounting bracket.

Installing the base cabinet for machines with a GiO plinth

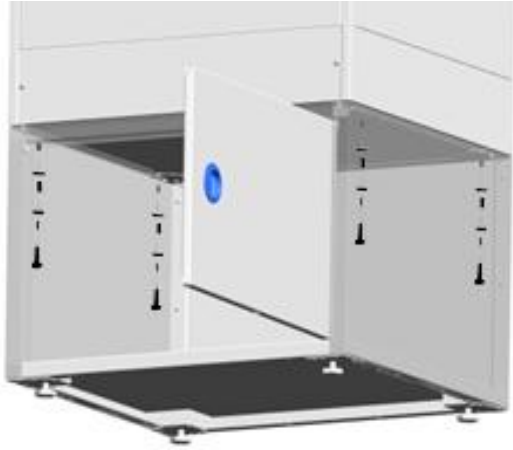
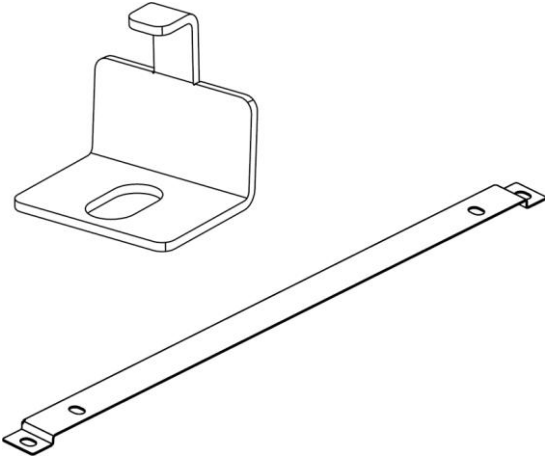
 <p>1. Remove the machine feet on the GiO plinth.</p>	 <p>2. Place the machine on the base cabinet and fasten it with washer, spring washer and M8 screw (4x).</p>
 <p>3. Fasten the machine to the floor with the retaining plate. For machines with ground clearance, use a mounting bracket.</p>	

Options

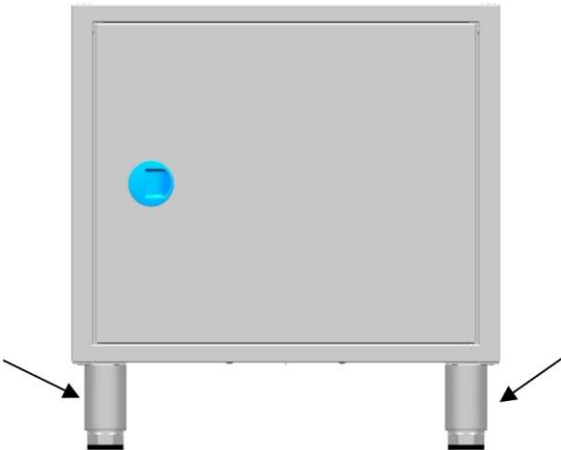
	<p>Raised screw-on feet</p> <p>Variants:</p> <ul style="list-style-type: none">• 125–180 mm height• 160–255 mm height
---	---

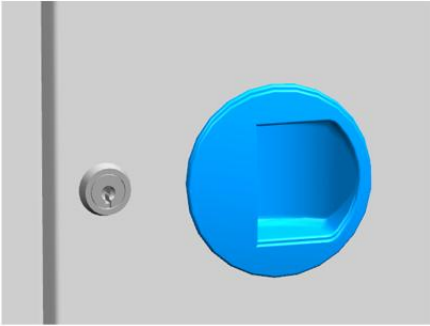
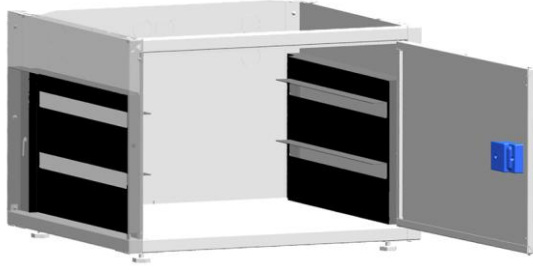
	<p>Door with lock</p>
	<p>Rack shelf walls</p>

Installing rack shelf walls (optional)

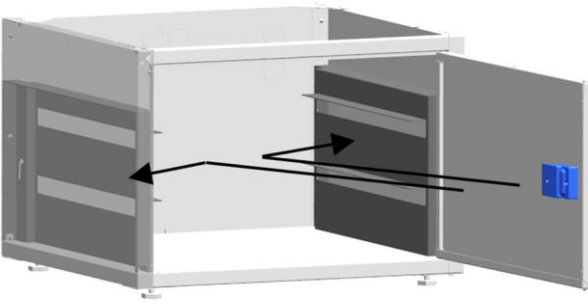
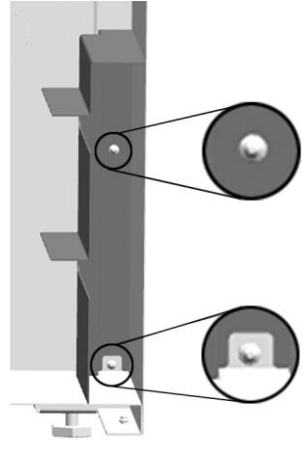
 <p>1. Insert the rack shelf walls. The attached cylinder head screw, which is used for fixing in the cabinet, must be at the front for installation.</p>	 <p>2. Pay attention to the recesses for the rivet heads during installation.</p>
--	--

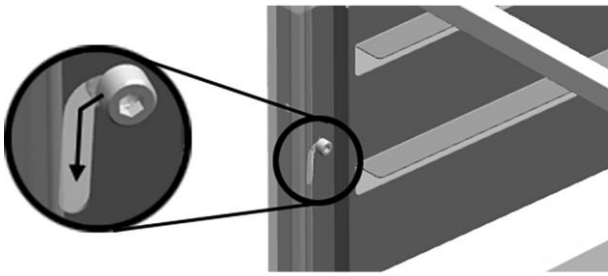

3. Push the cylinder head screw for locking downwards in the guide until it jams against the base cabinet.

Changing the door hinge side

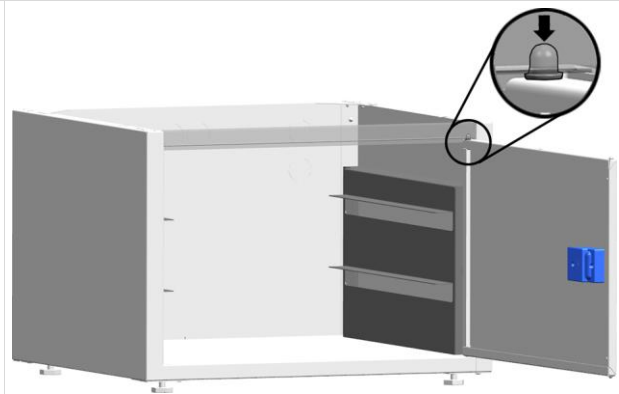
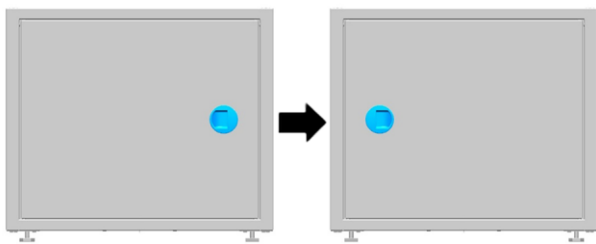

The door hinge side can be easily changed.

To do so, press the spring-loaded upper hinge pin downwards and remove the door. Turn the door round and fit it on the other side. The hinge pins must engage in the hinge holes.

7.3 Installing the frame, roller plinth or slide rails

The frame provides a raised position for the machine and additional storage space. Roller plinth or slide rails make it easier to move the machine.

Frame

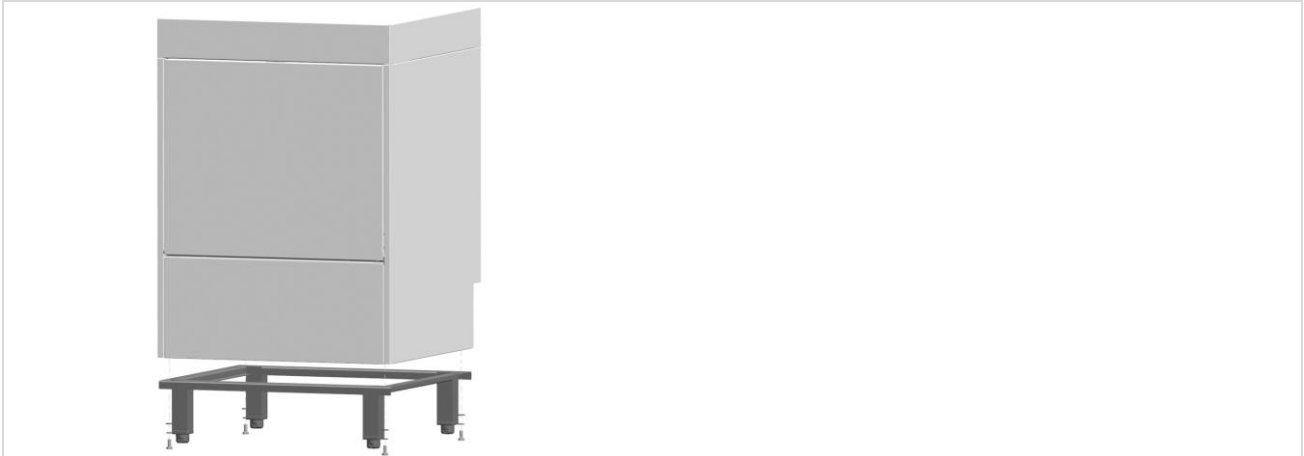

Remove the machine feet (4x) and fasten the frame with washer, spring washer and M8 hexagonal bolt (4x).

Roller plinth, 1-piece

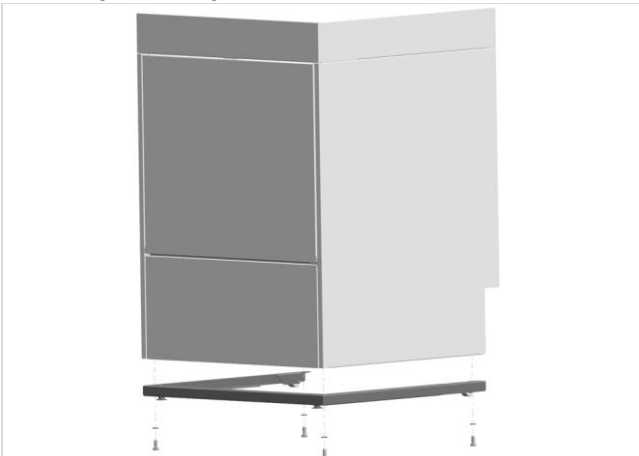

Remove the machine feet (4x) and fasten the roller plinth with spring washer and M8 hexagonal bolt (4x).

Roller plinth, 2-piece

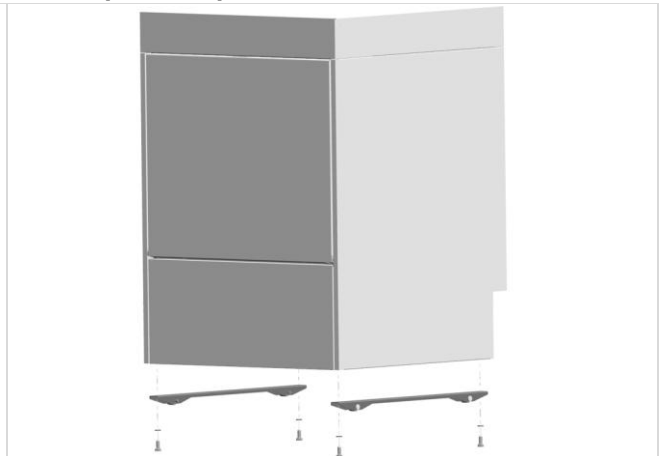

Remove the machine feet (4x) and fasten the two roller plinths with 2 spring washers and 2 M8 hexagonal bolts each.

Slide rails



Remove the protective film from the adhesive pad on the slide rail and align the slide rail over the recesses on the frame feet and stick it on (2x).

Empty plinth



Remove the machine feet (4x) and fasten the empty plinth with spring washer and M8 hexagonal bolt (4x). If machine feet are required, then use M8 hexagonal bolts (machine height +10 mm).

7.4 Connecting the dosing pipes to the machine

⚠ WARNING – Risk of injury from contact with chemicals

- Observe the safety data sheets and dosing recommendations of the chemical manufacturers.
- Use eye protection.
- Wear protective gloves.
- Do not mix different chemical products.

7.4.1 Connecting suction lances without empty-tank detection

Tool kit and material



Procedure



1. Connect the blue hose for rinse aid.
2. To secure in place, squeeze the clamp at the connection and release it at the correct position.



3. Connect the transparent hose for the detergent.
4. To secure in place, squeeze the clamp at the connection and release it at the correct position.
5. Secure both hoses for strain relief to the clip provided with a cable tie.



6. Punch a hole in the centre of each of the detergent and rinse aid canister covers.
Note: The hole must be large enough for pressure equalisation to take place.



7. Guide the suction lances into the canisters and through the hole in the canister cover. Screw on the canister covers tightly.



8. Connect the transparent hose to the suction lance in the white canister for detergent.
9. To secure in place, squeeze the clamp at the connection and release it at the correct position.



10. Connect the blue hose to the suction lance in the blue rinse aid canister.
11. Tighten the clamp on the connection.



12. Place the canisters for detergent and rinse aid according to the environment.

7.4.2 Connecting suction lances for empty level indication

Connecting suction lance dosing hoses and cables



1. Attach the labels for rinse aid (blue) and detergent (red) to the hose and cable of the suction lances using cable ties. The suction lances are identical in construction. The labels are used to distinguish the canisters.



2. Push the rinse aid and detergent suction lance hoses (blue or red label respectively) as far as they will go onto the correspondingly coloured labelled connection nozzles. Secure with the hose clamps.
3. Insert the rinse aid and detergent suction lance plugs (blue or red label respectively) into the corresponding colour-coded connection sockets.
4. Secure the hoses and cables of the two suction lances for strain relief to the clip provided with a cable tie.

**Note**

The rubber bung on the suction lance is suitable for canister openings with a diameter of between 30 mm and 37 mm. Larger canister openings require the installation of a canister lid:

Fitting the suction lance on the canister

1. Drill a 32 mm diameter hole in the centre of the canister lid using a step drill or peeler drill bit.



2. Press the rubber bung on the suction lance into the hole in the canister lid.
3. Insert the suction lance into the canister opening until it reaches the bottom of the canister, hold it at the top and screw on the canister lid.

**Note**

When using canisters > 5 l, the authorised MEIKO service technician must adjust the machine settings during commissioning.

7.5 Connecting the fresh water pump to the machine

1. Flush the inlet water hose to remove any impurities before attaching it to the machine. To do this, connect the inlet water hose to the shut-off valve, carefully open the shut-off valve and collect the water in a bucket.
2. Check the inlet water hose for damage.
3. Check that the seal is present.



4. Connect the bent end of the inlet water hose to the machine and tighten it with an open-end spanner.

7.6 Connecting the waste-water line



1. Connect the drain hose and tighten the clamp on the connection.



2. If necessary, extend the drain hose as shown.

7.7 Routing cables



1. Secure all hoses with cable ties.



2. Route the hoses according to the environment.

7.8 Aligning the machine and pushing it into niche



1. Press the black plastic ring onto the hexagonal bolt of the machine feet.



2. Unscrew the hexagonal bolt with the plastic ring to the desired length. Repeat the procedure for the other 3 machine feet.



3. Check the level of the machine with a spirit level at the top and sides and adjust the machine feet if necessary.



4. Push the machine into the niche.
Caution: Do not kink the hoses!



5. Make a custom finishing strip as required.

7.9 Making connections on site

7.9.1 Connect fresh water line



1. Connect the inlet water hose to the on-site connections.
2. Slowly open the shut-off valve and check that it is watertight. In the event of leaks, rectify the cause and check again for watertightness.

7.9.2 Connect waste-water line



1. Connect the wastewater hose to the on-site connection using a suitable drain fitting.

7.9.3 Connect electrically

⚠ WARNING – Danger to life from electric shock

- Work on the electrical system may only be carried out by a qualified electrician.
- Disconnect the machine from the power supply before working on the electrical system. To do this, turn the local mains switch to OFF and ensure that it cannot be switched back on again.

Connect the connection cable connected to the dishwashing machine to the on-site junction box.

8 Commissioning

After the machine has been connected electrically and to the water supply, request a MEIKO authorised service technician for handover.

This person must check the entire installation and carry out commissioning. Subsequently, the operating personnel is instructed on the basis of the handover protocol. The machine will then be signed over to your authorised representative.

9 Index

A

Assembly12

C

Checking the condition at delivery5

Commissioning31

Connection

electrical31

fresh water line31

waste-water line 29, 31

Connection dimensions7

D

Designation of machine type3

Dimensional drawings7

Dimensions7

E

Electrical connection10

F

Fresh water connection11

I

Installation9

Aligning the machine and pushing it into niche 30

Base cabinet 20, 24

Connecting the dosing pipes to the machine 25

Connecting the fresh water pipe to the machine28

Making connections on site31

Routing cables29

M

Machine weight6

N

notes3

P

Presentation conventions3

R

Recess dimensions7

Requirements for the fresh water connection 10

Requirements for the waste water connection ... 12

Requirements to the electrical connection9

Retrofitting the empty indicator 27

S

Safety4

Safety information4

Safety symbols in the instructions3

T

Technical data6



The clean solution



MEIKO Maschinenbau GmbH & Co. KG

Englerstraße 3

77652 Offenburg

Germany

www.meiko-global.com

info@meiko-global.com