

RF

Bi-cord conveyor for conveyor dishwashing machine

Original operating instructions

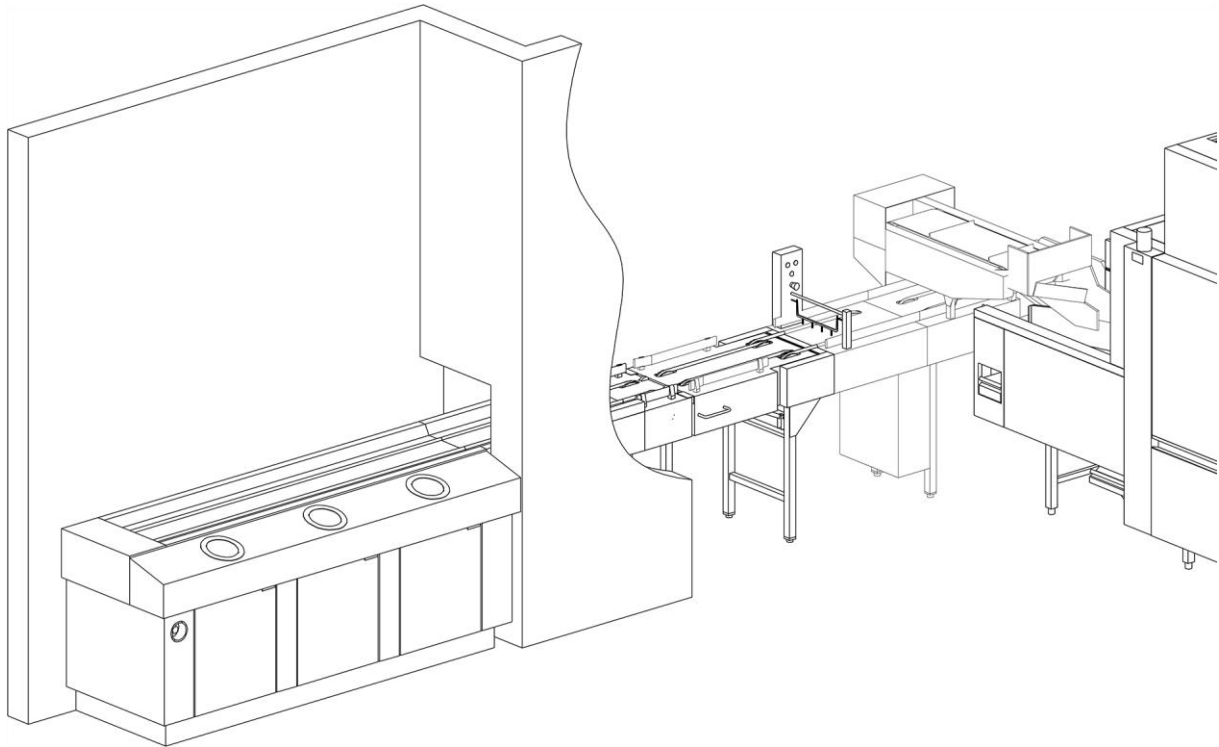

EN



Before using the machine, read carefully the operating instructions, the product description and the safety instructions.

Contents

1	NOTES ON THE OPERATING INSTRUCTIONS	4
1.1	Product identification	4
1.2	Delivery contents	4
1.3	Related documents	4
1.4	Presentation conventions	4
1.4.1	<i>Warnings</i>	4
1.4.2	<i>Notices on use</i>	4
1.4.3	<i>Award elements</i>	5
1.4.4	<i>Symbols</i>	5
1.4.5	<i>Illustrations</i>	5
2	DECLARATION OF CONFORMITY	5
3	SAFETY	6
3.1	Intended use	6
3.2	Foreseeable misuse	6
3.3	Safety information	6
3.4	Safety devices	8
3.4.1	<i>Emergency off function</i>	8
3.4.2	<i>Emergency stop function</i>	8
3.4.3	<i>Fire screen (optional)</i>	9
3.5	Safety labels and signs	10
3.6	What to do in the event of an emergency	10
3.7	Requirements for the personnel	10
4	PRODUCT DESCRIPTION	11
4.1	Functional description	11
4.2	Overview illustration	12
4.2.1	<i>Tray infeed station</i>	12
4.2.2	<i>Clearing area</i>	13
4.3	Control elements	14
4.4	Options	14
4.4.1	<i>Folding conveyor table</i>	14
4.4.2	<i>Height limitation</i>	15
4.4.3	<i>Cutlery lifting magnet</i>	15
4.4.4	<i>Tray merge</i>	15
4.4.5	<i>Tray infeed</i>	16
4.4.6	<i>Queue operation</i>	16
4.4.7	<i>Restricted operation</i>	16
4.4.8	<i>Key switch for bypassing restricted operation</i>	16
4.4.9	<i>Alternative transport speed</i>	17
4.4.10	<i>Signal lamp</i>	17
4.4.11	<i>Transport stop button</i>	17
4.4.12	<i>Deactivation function</i>	17
4.4.13	<i>Tray recognition</i>	18
4.4.14	<i>Tray position detection</i>	18
4.4.15	<i>Sight screen and noise absorbing tunnel</i>	18
4.5	Protective equipotential bonding	18

4.6	Workstations	19
5	TECHNICAL DATA	19
5.1	Technical limits	19
5.2	Ambient conditions	20
5.3	Requirements for the installation location	20
5.4	Requirements to the electrical connection	20
6	TRANSPORT	21
6.1	Disposal of packaging materials	21
7	ASSEMBLY AND COMMISSIONING	21
7.1	Fitting the conveyor body	22
7.2	Align machine feet	22
8	OPERATION/USE	23
8.1	Switching on the system	23
8.2	Resetting the emergency stop	23
8.3	Activate queue operation	23
8.4	Choose conveyor speed	23
8.5	Operating the folding conveyor table	24
8.6	Switching tray recognition	24
8.7	Bypass restricted operation	25
8.8	Switching off the system	25
8.9	Assistance in case of malfunctions	26
9	CLEANING	27
9.1	Clean tray infeed station and dish clearing area	27
9.2	Clean the return in the conveyor frame	28
9.3	Clean cutlery lifting magnet	29
10	MAINTENANCE	29
10.1	Maintenance plan	29
10.1.1	<i>Abbreviations used</i>	29
10.1.2	<i>Maintenance intervals</i>	29
10.1.3	<i>Maintenance work with the conveyor system switched off</i>	30
10.1.4	<i>Maintenance work with the conveyor system switched on</i>	30
11	DISMANTLING AND DISPOSAL	30
11.1	Dismantling and disposal of the old device	30
12	INDEX	31

1 Notes on the operating instructions

The operating instructions as well as the applicable documents must be read before the first commissioning, kept for later use, and must be accessible to the operator at all times. Failure to observe the operating instructions may result in damage to persons and property.

These operating instructions can be downloaded via the following address:
www.meiko.com or <https://partnetnet.meiko-global.com>.

1.1 Product identification

These operating instructions apply to the following machine types:
RF bi-cord conveyor

1.2 Delivery contents

The delivery contents include:

- Bi-cord conveyor, according to order
- Documentation, for details see Related documents

1.3 Related documents

In addition to these operating instructions, there are other documents that are available depending on the authorisation:

Operator/operating company (included in delivery contents)	
EC/EU declaration of conformity	Spare parts list
Wiring diagram	Assembly plan (in advance)
Documentation of further components specific to the order	

1.4 Presentation conventions

1.4.1 Warnings

⚠ DANGER – indicates an imminently hazardous situation which, if not avoided, will result in serious injury or death.

⚠ WARNING – indicates a potentially hazardous situation which, if not avoided, could result in serious injury or death.

⚠ CAUTION – indicates a possible hazardous situation which, if not avoided, could result in minor or moderate injury or damage to property.

1.4.2 Notices on use







Note – indicates useful and important information about the product or its use.

1.4.3 Award elements

Description of the markup elements used in this document:

- ✂ Required tool for subsequent action instruction.
- ▶ Requirement to be met for subsequent action instruction.
- 1. Successive action steps.
- ↳ Interim result for individual action steps.
- ✓ Final result of an action instruction.
- A bullet point designates a list.
- [] Terms in square brackets indicate keys.
- (1) Position numbers shown in parentheses in the text refer to position numbers in illustrations.

1.4.4 Symbols

	Read document		Potential equalisation connection
	Caution		Manufacturer

1.4.5 Illustrations

The illustrations contained in this document are not necessarily true to the original or to scale. The illustration may deviate from the original, e.g. due to modifications to the product, but without diminishing the facts or comprehensibility.

2 Declaration of conformity

This section reproduces the content of the EC/EU Declaration of Conformity for the product. The signed EC/EU Declaration of Conformity with serial number is enclosed with the product.

We hereby declare under our sole responsibility the conformity of the product with the essential requirements of this EC Directive:

- 2006/42/EC Machinery Directive, OJEU L157/24

Furthermore, we declare the conformity of the product with the following EU directives:

- 2014/30/EU Directive on Electromagnetic Compatibility, OJEU L96/79, 29/03/2014
- 2011/65/EU Directive on the restriction of the use of certain hazardous substances in electrical and electronic equipment, OJEU L174/88, 01/07/2011
- The safety objectives set out in the Low Voltage Directive 2014/35/EU (OJEU L96/357, 29/03/2014) were met in accordance with Annex I, No. 1.5.1 of the Machinery Directive.

3 Safety

3.1 Intended use

The bi-cord conveyor is designed exclusively for transporting suitable trays with dishes in the commercial sector.

The bi-cord conveyor may only be operated if it is in perfect working order.

The bi-cord conveyor may only be operated by trained personnel.

The bi-cord conveyor is not authorised for operation in a potentially explosive environment. Modifications or conversions to the bi-cord conveyor and the control system are not permitted.

3.2 Foreseeable misuse

The bi-cord conveyor must not be used for the transport of:

- Living creatures
- Kitchen utensils with electronic components
- Textiles, oven cloths or steel sponges
- Utensils that must not come into contact with foodstuffs (e.g. ashtrays, candlesticks, etc)
- Hot objects

The maximum permissible load on the conveyor belt must not be exceeded.

3.3 Safety information

The product has been manufactured in line with the state of the art and the established safety regulations and standards. Nevertheless, its use may result in functional hazards to the life and limb of the user or third parties. Therefore, read and observe the following safety notices before using the product.

Strong permanent magnet in the cutlery lifting magnet (optional)

Strong permanent magnets are installed in the cutlery lifting magnet. They can affect the function of pacemakers and implanted defibrillators. A magnetic pulse could switch the pacemaker to a different mode. A defibrillator may no longer function.

- Observe safety signs.
- If you have a pacemaker or an implanted defibrillator, keep a minimum distance of 0.6 metres.
- Warn wearers of such active implants if necessary.

Electric shock due to live parts!

Live parts are freely accessible when the housing parts are open. Touching live parts can lead to serious electric shocks and injure or kill people.

- Have work on the electrical system carried out only by MEIKO authorised service technicians or a qualified specialist workshop.
- Before opening housing parts, always switch off the main switch and secure it against being switched back on.
- Have damaged insulation and components of the electrical system repaired immediately.
- Have damaged power cables replaced immediately.

Wear personal protective equipment!

Missing or unsuitable personal protective equipment increases the risk of health effects and injury to people.

- Define and provide personal protective equipment for the respective application.
- Only use personal protective equipment that is in proper condition and provides effective protection.
- Adapt personal protective equipment to the person, e.g. size.
- Personal protective equipment includes, for example
 - Work gloves
 - Safety shoes
 - Safety glasses
 - Protective clothing

Wear suitable clothing!

Loose clothing increases the risk of being caught or wound up on rotating parts and the risk of getting caught on protruding parts. This can severely injure people.

- Wear fitted clothing.
- Never wear rings, necklaces or other pieces of jewellery.
- Wear a hairnet for long hair.
- Wear sturdy shoes or safety footwear.

Make sure safety labels and signs remain legible!

Safety labels and signs on the machine provide warning of hazards at danger points and are important components of the machine's safety equipment. A lack of safety labels and signs increases the risk of serious and fatal injuries to people.

- Clean soiled safety labels and signs.
- Damaged and unrecognisable safety labels and signs must be replaced immediately.

Make sure protective devices remain functional!

If protective devices are missing or damaged, people can be seriously injured or killed.

- Replace damaged protective devices immediately.
- If the protective devices are damaged, shut down the machine.
- Never tamper with, bypass or override protective devices.
- Assemble dismantled protective devices and other parts before commissioning and move them into the protective position.

3.4 Safety devices

3.4.1 Emergency off function

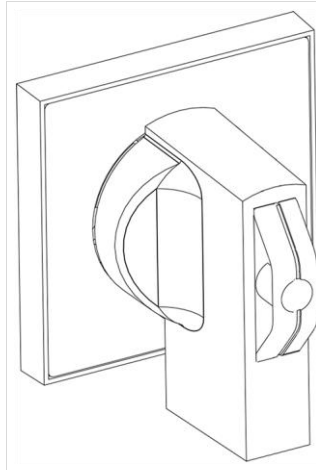

The main switch is designed as an emergency off function. The emergency off function interrupts the power supply to the system. It can be secured against being switched on again.

The emergency off button is located on the control cabinet. It must be easily accessible and free of obstacles at all times.

3.4.2 Emergency stop function

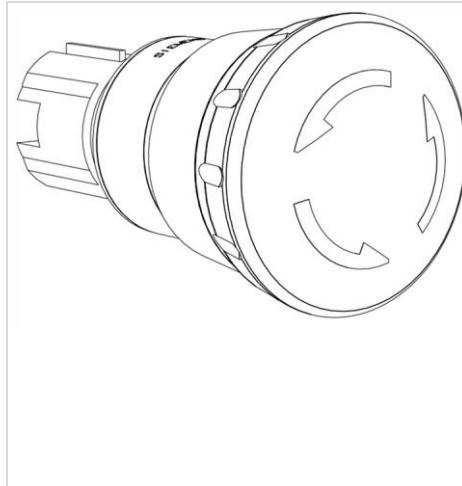

Emergency stop function. Triggering the emergency stop function stops the conveyor system. If the conveyor system is divided into sections, the emergency stop function first acts on the affected section. Upstream sections are shut down if necessary by the deactivation function. After eliminating the cause of the fault, unlock the emergency stop button and press the **[On]** button.

The emergency stop buttons must be easily accessible and free of obstacles at all times. The emergency stop buttons must not be used to switch off the conveyor system!

3.4.3 Fire screen (optional)

If a conveyor system runs through several structurally delimited fire compartments, fire screens prevent the fire from spreading across the respective fire compartment in the event of a fire.

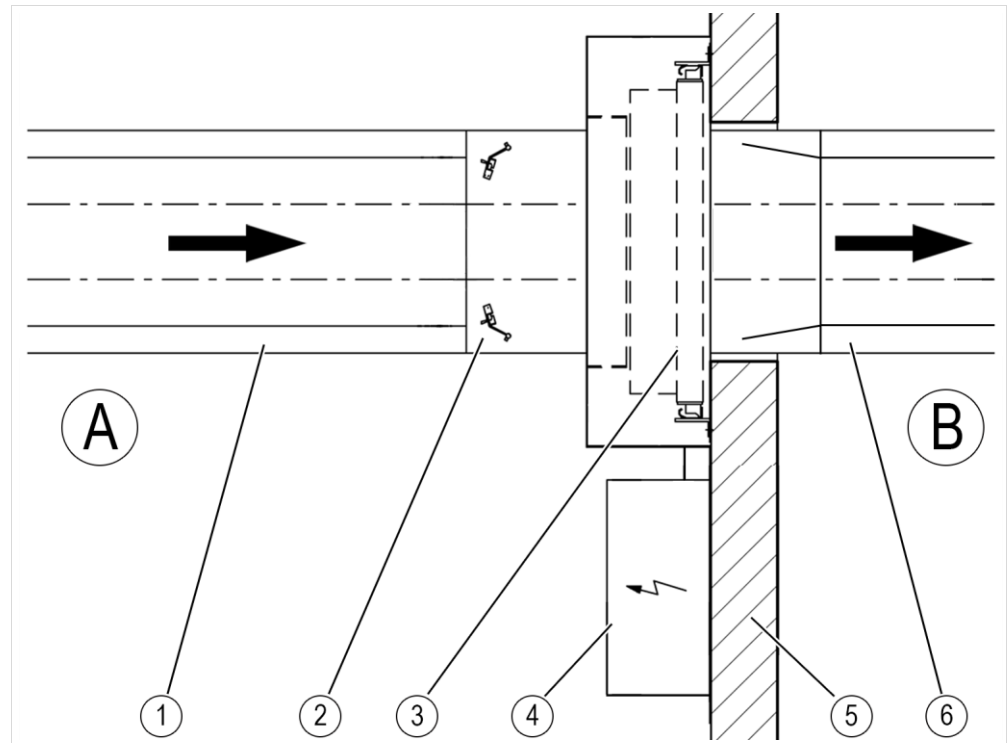

A fire screen consists of a conveyor system closure for spatial separation (3) between two fire compartments (A and B) and a hold-open system for the mains-independent control system (4). The hold-open system makes sure that the safety device functions reliably in the event of a fire.

To ensure that no tray obstructs the conveyor system closure (3) in the event of a fire, the conveyor belt is released. This can be implemented in two ways:

- A mechanical restraining device (2) holds back trays in front of the conveyor system closure (3) in the event of fire, while the conveyor belt (1) continues to run freely.
- A control technology free travel device stops the conveyor belt (1) with trays in front of the conveyor system closure (3). The subsequent conveyor section (6) continues to run for a defined period of time until the belt section below the conveyor system closure is free.

The exact design and position of the fire screen can be found in the assembly plan.



Note

The function of fire screens must be checked regularly. In addition, a visual inspection must be carried out after each closing process, e.g. to remove dishes from the closing area.

3.5 Safety labels and signs



3.6 What to do in the event of an emergency



- In dangerous situations, press the emergency stop function or disconnect from the power supply using the locally available main switch.

3.7 Requirements for the personnel

Commissioning, instructions, repairs, maintenance, assembly and installation of or on MEIKO products may only be carried out/authorised by authorised service partners.

During operation it must be ensured that:

- Only adequately trained and instructed personnel are allowed to work on the machine.
- Personnel responsibilities for operation, maintenance and repairs must be clearly defined.
- Any personnel undergoing training are only allowed to work on the machine under the supervision of an experienced person.

Qualified personnel as defined by this document are persons who:

- Over 14 years of age.
- Due to their training, experience and instruction are able to perform the required activities.
- Are authorised to perform the required activities by the person responsible for safety of the system.
- Have read and understood the operating instructions and corresponding safety information and will follow them.

The required qualifications for performing specific work at the machine are determined by MEIKO:

Activity	People	Trained operating staff	In-house technician authorised by MEIKO	Service technician authorised by MEIKO
Installation/assembly				✓
Commissioning				✓
Operation, use		✓	✓	✓
Cleaning		✓	✓	✓
Checking safety devices			✓	✓
Troubleshooting		✓	✓	✓
Error clearance, mechanical		✓	✓	✓
Error clearance, electrical			✓*	✓
Maintenance			✓	✓
Repairs			✓	✓

* with training as an electrician



Note

The instructions must be acknowledged in writing.

4 Product description

4.1 Functional description

The bi-cord conveyor transports trays along a conveyor section from the tray infeed station to the clearing area. The entire conveyor section is divided into belt sections. Each belt section has a driven round belt.

At the tray infeed station, the trays with dishes are placed on the round belts. The trays are transported to the clearing area, where the staff remove the dirty dishes and feed them into the dishwashing machine. At the end of the conveyor section, the staff remove the empty trays, or alternatively they are taken to a stacking unit or a dishwashing machine.

4.2 Overview illustration

Bi-cord conveyor. (Figure as an example)

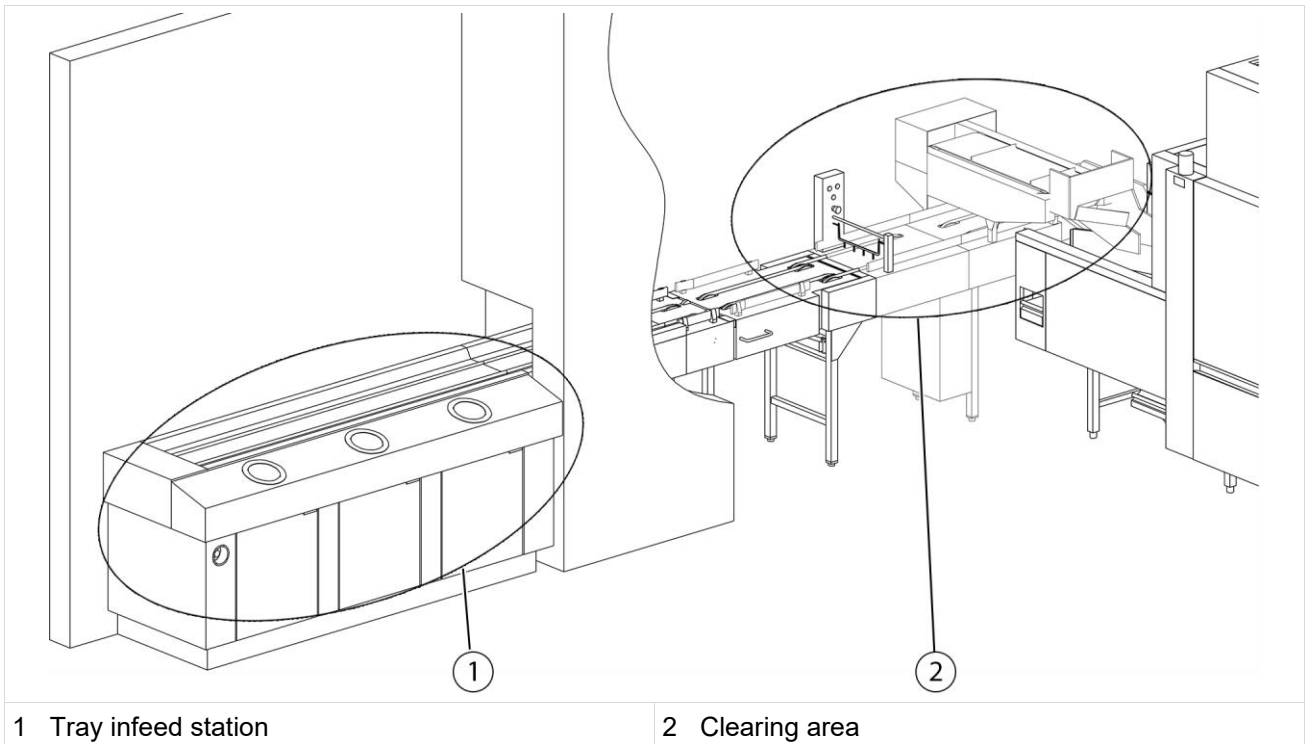

4.2.1 Tray infeed station

The tray infeed station is located at the start of the bi-cord conveyor and usually in a publicly accessible area. Depending on the configuration of the conveyor system, the tray infeed station can also be located in the dishwashing area. (Figure as an example)

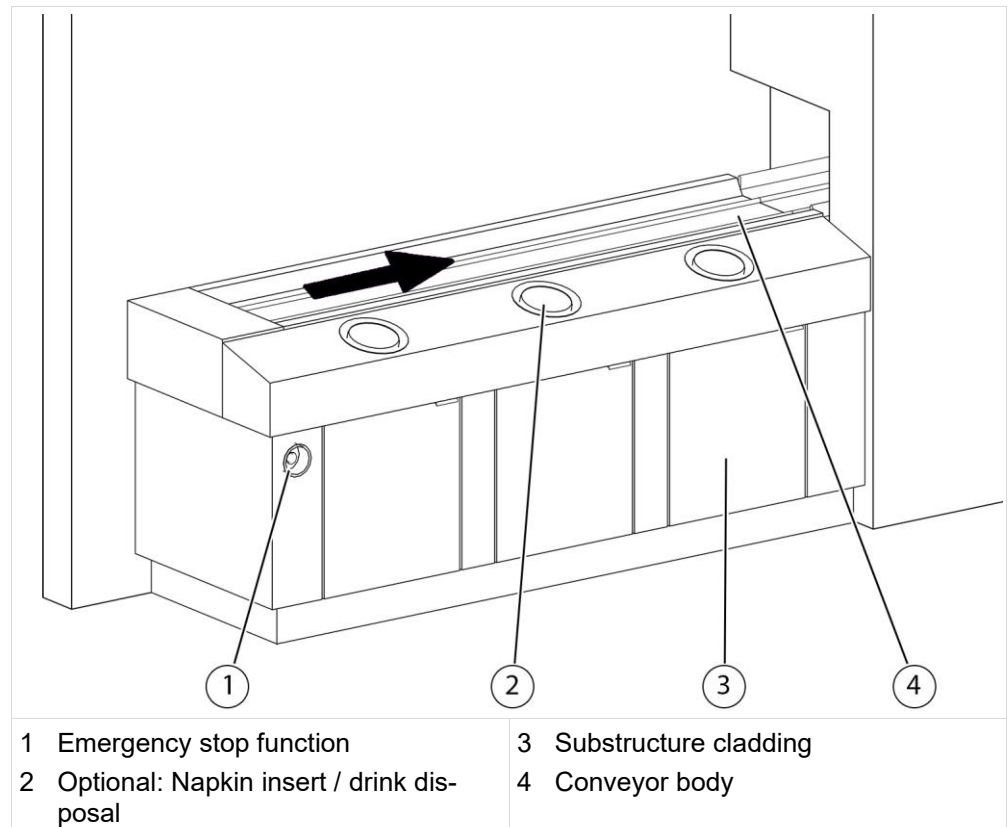



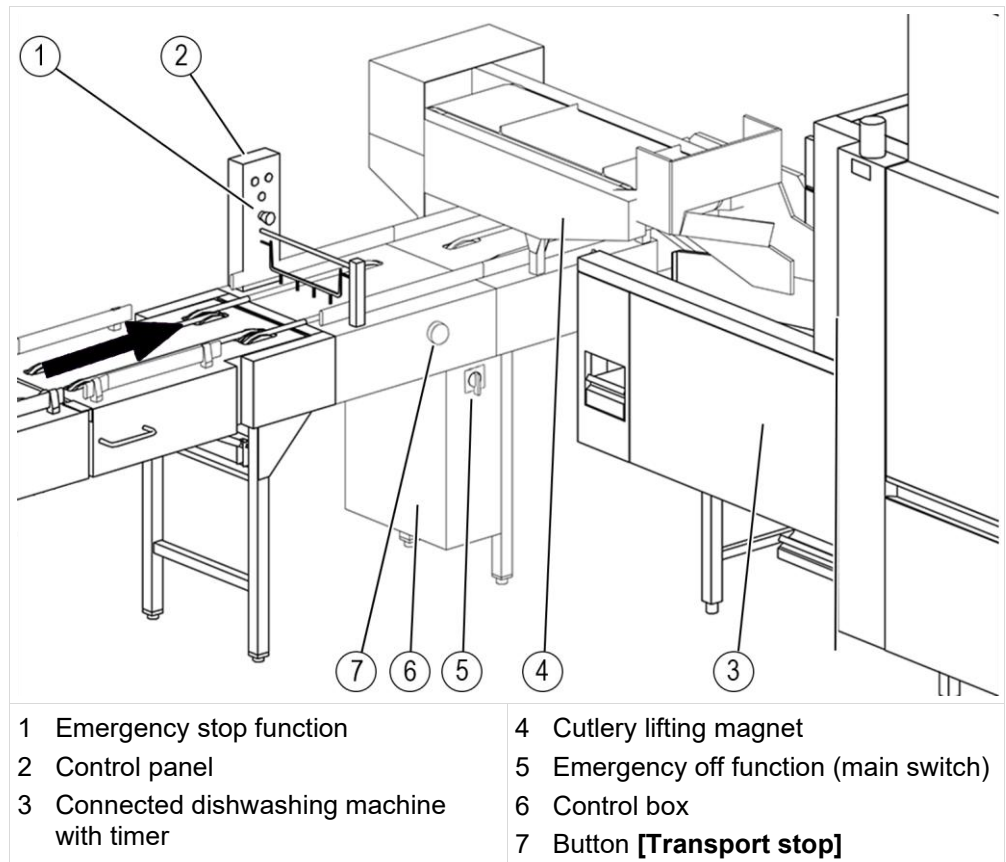

4.2.2 Clearing area

In the clearing area, incoming trays are cleared by trained staff and dirty dishes are fed into the dishwashing machine.



4.3 Control elements

Symbol	Description
Standard control elements	
I	The [On] button starts the bi-cord conveyor. The button lights up white when it is pressed.
O	The [Off] button stops the bi-cord conveyor. When the button is pressed, the [On] button goes out.
//	The [Acknowledge] button lights up blue if: <ul style="list-style-type: none"> the emergency stop is pressed, the cutlery collector (optional) is full. Once the action has been carried out, it must be confirmed using the [Acknowledge] button so that the conveyor belt starts up again. The lights go out. The [Acknowledge] button is only available in conjunction with existing effective ranges and/or a dish collector.
Optional control elements	
▶▶▶	Toggle switch for switching the transport speed.
	Toggle switch for switching to queue operation.
	Tray recognition. Toggle switch for switching between two tray versions.
	Tray merge Toggle switch for switching the respective incoming tray track.
	[Transport stop] button on the dishes clearing areas (optional). The button lights up white when it is pressed.

4.4 Options

Depending on the order-specific design, various optional modules or functions may be included.

4.4.1 Folding conveyor table

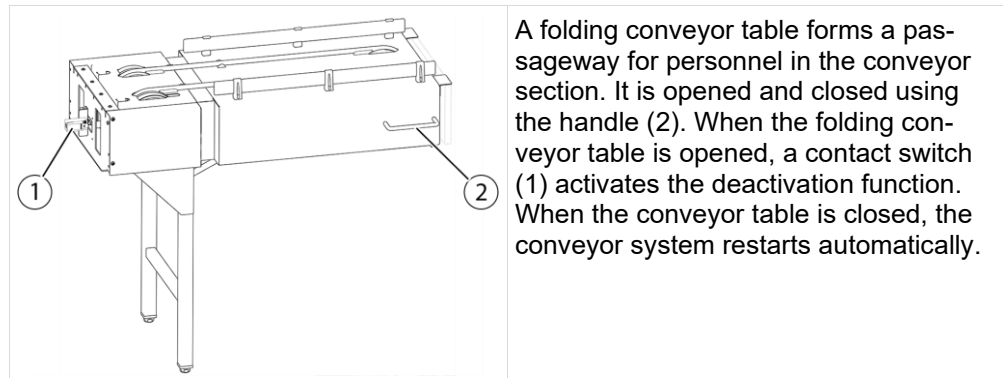

4.4.2 Height limitation

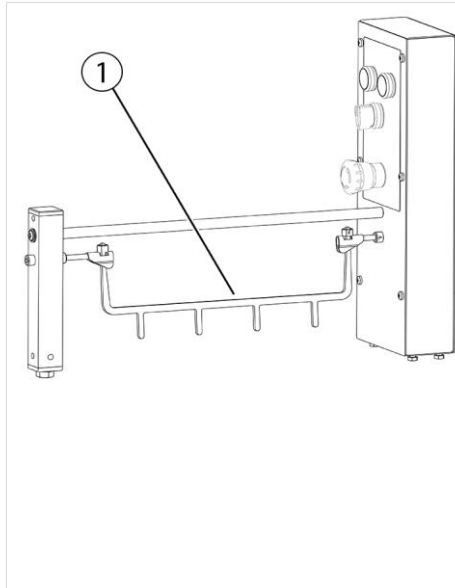

The switching rod (1) picks up dishes on the tray that are higher than the edge of the tray. Then the conveyor system stops.

Once the tray has been cleared, the height limitation is released and the conveyor system is restarted.

The height limitation functions independently of the transport speed and set operating mode. It can be mechanical or optical, as shown in the figure.

Possible positions:

- Upstream of a stacking unit
- Upstream of dishwashing machine infeed

See assembly plan. (Figure as an example)

4.4.3 Cutlery lifting magnet

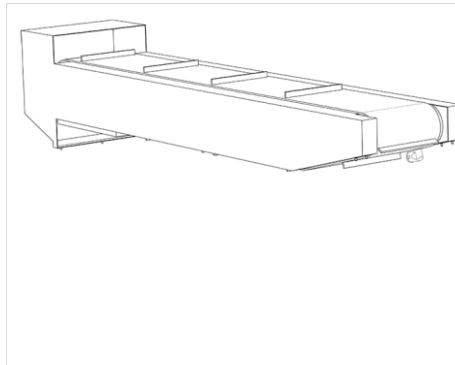

The cutlery lifting magnet (figure as an example) lifts magnetic cutlery items from the tray and conveys them via a belt conveyor into a connected conveyor dishwashing machine or into a cutlery soak trolley.

If a conveyor dishwashing machine is connected, it switches on the cutlery lifting magnet. Otherwise, the cutlery lifting magnet is switched on by the conveyor system.

4.4.4 Tray merge

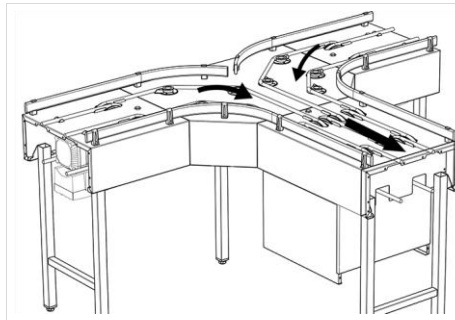

A tray merge brings together trays from two conveyor sections. The transport speeds of the feeding conveyor sections can be different.

Optional toggle switch for switching between the two infeed conveyor sections. Then one conveyor section stops at a time.

4.4.5 Tray infeed

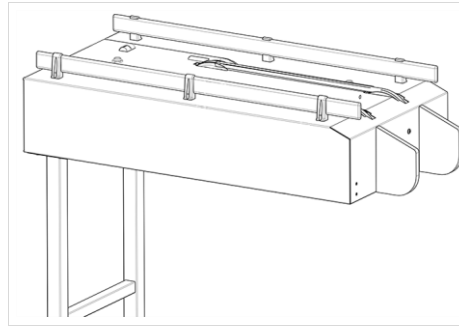

The tray infeed is located at the feeding section of the connected flight type dishwashing machine. It ensures that the cleared trays are automatically fed into the flight type dishwashing machine. (Figure as an example)

4.4.6 Queue operation

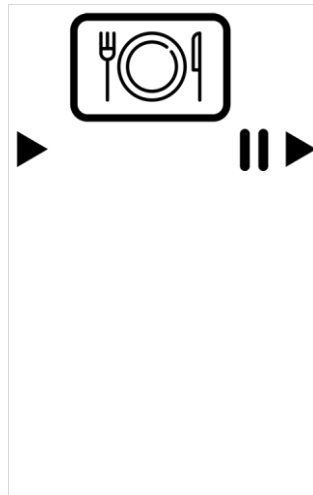

The queue operation is switched at the control panel using a toggle switch. It is active immediately. Alternatively, it can be activated and deactivated on the touchscreen.

In active queue operation, trays are accumulated section by section, starting after the tray on-set section, until the entire conveyor section is full.

The conveyor system stops and a signal sounds. Switching to continuous operation deactivates the acoustic signal and restarts the conveyor system. The accumulated trays then move continuously to the dishwashing area.

4.4.7 Restricted operation

Restricted operation is activated automatically if a conveyor dishwashing machine connected to the conveyor system stops. This ensures that the pre-installed conveyor section continues to run. Only when the sensor detects a tray before automatic cutlery processing, the pre-installed conveyor section is also stopped (if necessary with the deactivation function).

The conveyor section restarts when:

- The tray on the sensor is removed.
- The dishwashing machine transport starts up again.

4.4.8 Key switch for bypassing restricted operation

Restricted operation is bypassed with the key switch. When the key switch is activated, the conveyor system continues to run without interruption and transports trays from the tray infeed station to the dishwashing area. The cutlery items must be manually removed from the tray before the cutlery lifting magnet. The yellow signal lamp on the control panel lights up when the key switch is activated.

The key switch must be deactivated as soon as the conveyor dishwashing machine is working again.

4.4.9 Alternative transport speed

	<p>The transport speed is switched at the control panel using a toggle switch or on the touchscreen and is immediately active. It affects the entire conveyor system.</p> <p>Symbols on the control panel:</p> <p>(1) Slow transport speed, e.g. with low capacity utilisation.</p> <p>(2) Faster transport speed, e.g. with higher capacity utilisation.</p>
---	---

4.4.10 Signal lamp

The amber signal lamp is located on the control panel. It has the following function:

	<p>Restricted operation bypassed</p> <p>The signal lamp lights up as long as restricted operation is bypassed.</p>
---	---

4.4.11 Transport stop button

	<p>One or more buttons [Transport stop] may be present on the dish clearing stations.</p> <ul style="list-style-type: none">• The buttons stop the respective effective range• When a button is pressed, all buttons light up white• The conveyor belt is restarted by pressing any button [Transport stop]
--	---

4.4.12 Deactivation function

The deactivation function is a section-by-section shutdown of the conveyor system. When the deactivation function is activated, the affected belt section stops. As soon as a tray reaches the belt section before the stopped belt section, this also stops. Gradually, all belt sections stop until the tray infeed station. If the deactivation function is deactivated, the belt sections start up again.

The following elements activate the deactivation function:

- Folding conveyor table
- Height limitation
- Safety switch on tunnel flaps
- Connected dishwasher stops
- Tray merge

4.4.13 Tray recognition

The toggle switch for switching between two tray versions activates the respective sensors for detecting dishes on the different trays.

Functioning:

The sensors detect the transported trays after the clearing area. They detect whether there are any dishes left on the trays and stop the conveyor belt if a tray has not been completely cleared. Once the tray has been removed, the conveyor belt starts up again.

It is important to ensure that asymmetrical trays, such as trapezoidal trays, are always placed in the correct position.

4.4.14 Tray position detection

Sensors in the clearing area detect whether asymmetrical trays have been placed in the correct position.

- If an asymmetrical tray is detected in the wrong position, the conveyor belt stops.
- The conveyor belt restarts when the tray is moved into the correct position.

4.4.15 Sight screen and noise absorbing tunnel

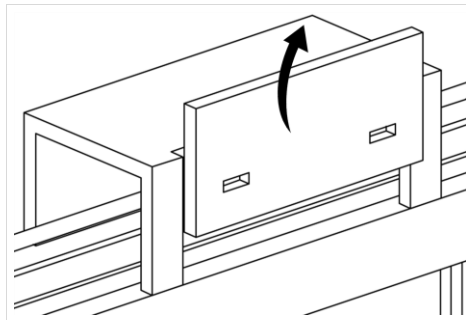

Sight screen and noise absorbing tunnels cover the conveyor sections for a demarcated area. They can be fitted with removable flaps at the front (see figure) or with removable lids.

4.5 Protective equipotential bonding

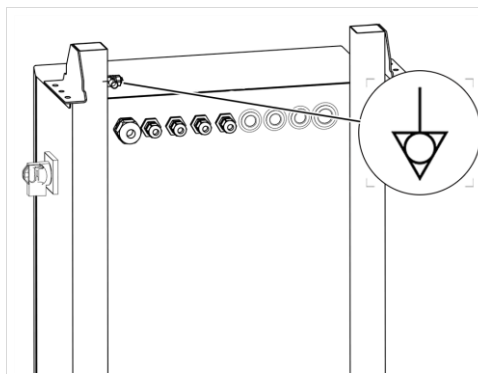

Protective equipotential bonding on the control box. Additional connections for protective equipotential bonding may be available on the bi-cord conveyor. See assembly plan.

(Figure as an example)

4.6 Workstations

The tasks at the work stations depend on the degree of automation:

The degree of automation (1/2/3, see table) is determined by the component(s) connected to the bi-cord conveyor, such as dishwashing machine, cutlery lifting magnet and/or tray stacking trolley. This results in the respective tasks at the work stations.

Tasks depending on the degree of automation	1	2	3
Clear and dispose of leftovers and waste from the dishes.	x	x	x
Clear dishes from the trays and place them on the dishwashing machine belt.	x	x	x
Clear the cutlery and place it on the cutlery track or in the cutlery quiver of the dishwashing machine.	x	x	
Cutlery is lifted from the tray by the cutlery lifting magnet.			x
Remove the tray and send it for further cleaning.	x		
Empty trays are automatically transported into a dishwashing machine or onto a tray stacking trolley.		x	x

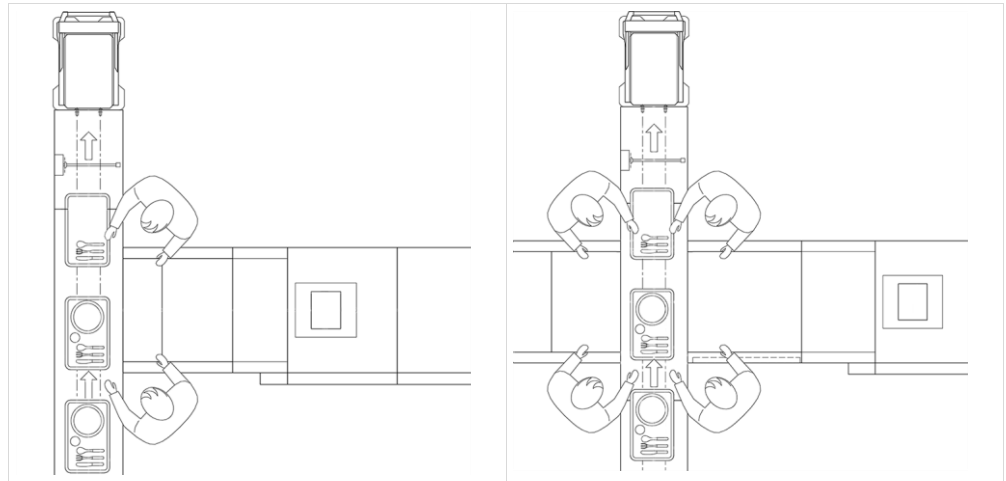

Examples of typical work stations for automation level 2:

- 2 work stations with standard feeding section (left, figure as an example)
- 4 work stations with lowered feeding section (right, figure as an example)

5 Technical data

5.1 Technical limits

Technical limits	
Permissible tray size	
Length	425-530 mm
Width	325-370 mm
Maximum load	5 kg/m
Transport speed	4-25 m/min
Sound pressure level	≤70 db(A)
Protection class	IPX5

5.2 Ambient conditions

Ambient conditions	
Operating temperature	5 ... 40°C
Relative humidity	< 95%
Storage temperature	5 ... 40°C
Maximum height of the installation site above sea level	2000 m

5.3 Requirements for the installation location

- Consistently frost free storage and installation site
- Install anti-slip floor coverings in the work area

5.4 Requirements to the electrical connection

For Australia and New Zealand only:

All work carried out must be in accordance with AS/NZS 3000!

Electrical connection must be carried out in accordance with the locally applicable regulations (e.g. HD 60364-1/IEC 60364-1/VDE 0100-100) so the machine can be connected to the mains supply in accordance with the installer's regulations. However, national installer's regulations may differ. The machine and accessory appliances are intended for permanent connection to the on-site power supply and the on-site protective equipotential bonding and have been tested accordingly before being brought to market.

Fuse and backup protection

- Set up the machine according to the local conditions and according to the rated current (see rating plate) as a separately fused circuit (final circuit) so that backup protection is guaranteed. Take note of the available connection variants.

Main switch/mains connection cable

- The main switch must be easily accessible for the operating personnel at all times.
- The contact opening width must correspond to overvoltage category III in each pole.
- Mains power cables must be oil-resistant, sheathed, flexible cables no lighter than a normal polychloroprene-sheathed cable (or other equivalent synthetic elastomer) with the marking 60245 IEC 57.

Electrical safety

- The electrical safety of this machine is only ensured if it is connected to a properly installed protective conductor system. It is very important to verify this fundamental safety feature. If in doubt, have the building wiring checked by an electrician.
- The protective measures and the connection of the equipotential bonding of the system and all its components (tables, feed units, belts) must be carried out in accordance with the local regulations and the requirements of the local utility companies.

6 Transport



Note

The machine may only be transported by a service technician authorised by MEIKO!



Note

For safe transport, separate the machine at the connection points and secure the individual components on pallets. See assembly plan for information.

6.1 Disposal of packaging materials

All the packaging materials are recyclable. The following materials are used:

- Square timber frame
- Plastic sheeting (PE film)
- Foam material
- Cardboard packaging (edge protection)
- Packaging strap (steel strip)
- Packaging strap (plastic (PP))
- If needed, transport safety bracket (stainless steel)

7 Assembly and commissioning



Note

Assembly and installation may be performed only by a service technician authorised by MEIKO.

CAUTION – Risk of injury from sharp edges.

- Wear protective gloves (waterproof and cut resistant).

7.1 Fitting the conveyor body

✂ Flat spanner, SW 10 mm

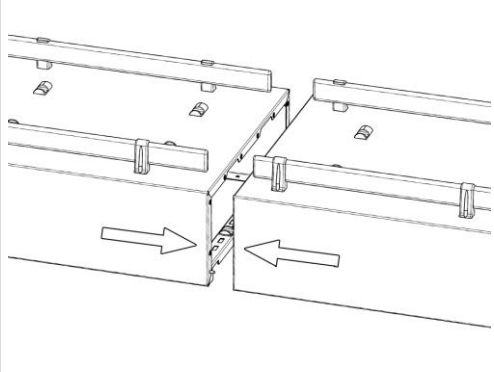
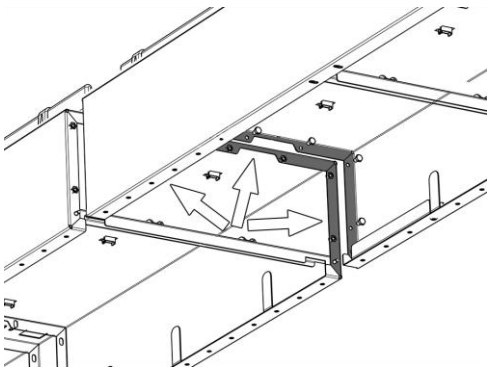
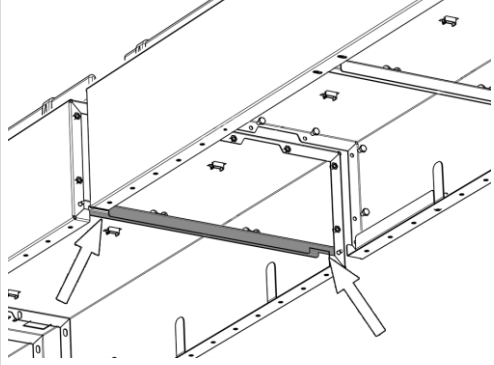
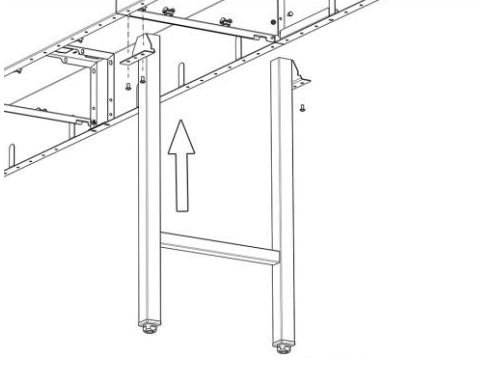
	
<p>1. Position the conveyor bodies in relation to each other at the installation site.</p>	<p>2. Screw the conveyor bodies together at the joint (arrows) using the enclosed screws and nuts.</p>
	
<p>3. Position the brace (arrows) and tighten the screws.</p>	<p>4. Fit the machine feet to the bottom of the conveyor body.</p>
<p>5. If necessary, repeat the steps for other conveyor bodies. ✓ The conveyor bodies are mounted and can now be aligned.</p>	

7.2 Align machine feet

✂ Flat spanner, 29 mm

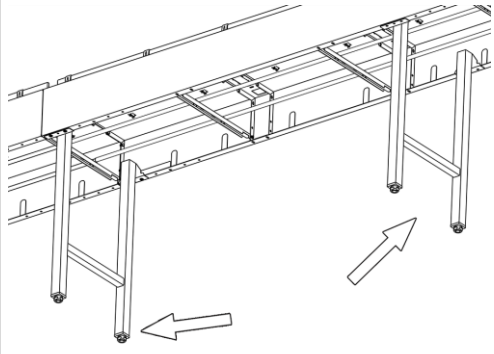
	<p>► The conveyor bodies are mounted.</p> <ol style="list-style-type: none">1. Place the spirit level on the conveyor body.2. Use a flat spanner to adjust the machine feet until the conveyor body is levelled and aligned according to the assembly plan. <p>✓ The machine feet are aligned.</p>
---	---

8 Operation/use

8.1 Switching on the system

- ▶ The bi-cord conveyor is switched off.
 1. Switch on the main switch.
 2. Press the **[On]** button.
- ✓ The bi-cord conveyor and all connected components are switched on. The round belts are running. Trays can be placed at the feeding station.



Note

The conveyor dishwashing machine must be switched on for the conveyor system to run.

8.2 Resetting the emergency stop

- ▶ The emergency stop button has been pressed.
 1. Eliminate the reason for the emergency stop.
 2. Unlock the emergency stop button by turning it.
 3. Check the safety devices for correct condition.
- ✓ The machine is ready for operation.

8.3 Activate queue operation

The operating mode can be switched at any time. Optional extra.

- ▶ Continuous operation is active.
 1. Set toggle switch for operating modes to queue operation.
- ✓ Queue operation is active.

8.4 Choose conveyor speed

The transport speed of the round belt can be switched during operation. Optional extra.

- ▶ The conveyor system has a speed switching function.
 1. Set the toggle switch for speed to a different speed.
- ✓ The transport speed of the round belt adapts immediately to the setting. If the speed is switched when the conveyor system is switched off, the round belt runs at the set speed after being switched on.

8.5 Operating the folding conveyor table

⚠ CAUTION - Risk of crushing when operating the folding conveyor table!

- Always operate the conveyor table using the handle.
- Do not reach between the moving elements of the conveyor table.

The conveyor table can be opened and closed during operation.

- ▶ There are no trays or other objects on the conveyor table.

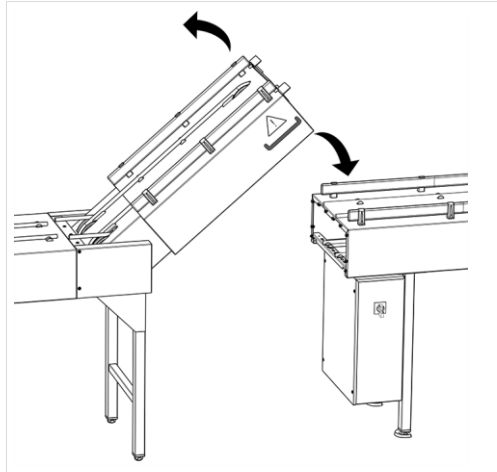

1. Fold the conveyor table upwards using the handle until it is in the end position.
 - ↳ If the conveyor table is opened during operation, the conveyor belt stops.
2. Close the conveyor table using the handle until it rests in the end position.
 - ✓ When the conveyor table is closed, the conveyor belt starts to run again.

8.6 Switching tray recognition

If the toggle switch is not set to the correct position for the tray design when the conveyor system is switched on, trays are not detected or are detected incorrectly and the conveyor system stops.

- ▶ The tray recognition option is available.
1. When switching on the conveyor system, check the position of the toggle switch for tray detection.
 2. If necessary, switch the toggle switch for tray detection to the tray version of the trays used.
 - ✓ The sensors for the tray version are switched. The set tray detection remains active until it is switched over using the toggle switch.



Note

Mixed operation with different tray versions is not possible! When changing to the second tray version, the toggle switch must be changed.

8.7 Bypass restricted operation

In order to maintain operation of the conveyor system and continue transporting trays in the event of a prolonged failure of the conveyor dishwashing machine, restricted operation can be bypassed with a key switch on the control box (optional).

- ▶ A connected conveyor dishwashing machine has failed.
- ▶ Restricted operation is active. The conveyor belt stops when the sensor detects a tray before automatic cutlery processing.
 1. Activate the key switch.
- ✓ The conveyor system starts up again. Trays continue to be transported from the infeed area to the dishwashing area as long as the key switch is active.



Note

Caution: permanent magnet! When restricted operation is bypassed, all trays in front of the cutlery lifting magnet must be completely cleared by hand.



Note

The key switch must be deactivated as soon as the conveyor dishwashing machine is running again.

8.8 Switching off the system

- ▶ The bi-cord conveyor is switched on.
 1. Run the bi-cord conveyor empty.
 - ↳ The bi-cord conveyor is run empty section by section and the drives are switched off.
 2. Switch off the main switch.
- ✓ The bi-cord conveyor is switched off.

8.9 Assistance in case of malfunctions

The following malfunctions can be remedied by the operating personnel or the in-house technician.

Malfunction	Possible cause	Remedy
Round belt will not start.	Emergency stop function was pressed.	Remedy any faults. Unlock emergency stop function. Press the [Acknowledge] button, if available.
	Folding conveyor table not closed properly.	Close the folding conveyor table correctly, check the contact switch if necessary.
	Height limitation is activated.	Mechanical height limitation: Check the function of the switching rod. Optical height limitation: Check sensors for dirt and clean if necessary.
	Motor is defective.	Contact technical service.
	[Transport stop] button actuated. The button lights up.	Press the [Transport stop] button again.
Round belt stops.	Emergency stop function was pressed.	Remedy any faults. Unlock emergency stop function. Press the [Acknowledge] button, if available.
	Height limitation has been triggered.	Remove the object. The conveyor belt starts to run again.
	Deactivation function active because conveyor section full.	Clear conveyor section. The conveyor belt starts to run again.
	Sensors detect an incorrect tray or dishes that have not been cleared.	Clear the dishes, remove the wrong tray if necessary. Check the toggle switch position. After eliminating the cause, the conveyor belt starts up again.
	Motor is defective.	Contact technical service.
	A component following the conveyor system triggers the round belt to stop: <ul style="list-style-type: none"> Dishwashing machine Tray washer 	<ul style="list-style-type: none"> Eliminate the fault on the component. The conveyor belt starts to run again. Bypass restricted operation using the key switch on the control box (optional). The conveyor belt starts to run again. Clear trays by hand in front of the cutlery lifting magnet, remove trays if necessary.
	Tray stacking trolley: <ul style="list-style-type: none"> Missing Is full 	Eliminate the fault on the component. The conveyor belt starts to run again: <ul style="list-style-type: none"> Replace tray stacking trolley Position tray stacking trolley
	Tray detection at the end of the belt has been triggered.	Clear conveyor section. The conveyor belt starts to run again.
Tray position detection has been triggered.	Align or remove the tray correctly. The conveyor belt starts to run again.	

As a rule, malfunctions that are not described here require assistance from a service technician authorised by MEIKO. Please contact your subsidiary or an authorised dealer.

9 Cleaning

CAUTION – Material damage to electrics due to water ingress

- The machine, control cabinets and other electrical components must never be sprayed with a hose, a high pressure cleaner or a steam cleaner.
- Make sure that no water can enter the machine unintentionally.
- If installed at ground level, never flood the surrounding room.

CAUTION – Material damage to stainless steel due to incorrect cleaning

Cleaning of parts made of stainless steel with unsuitable detergents, care products and cleaning utensils leads to damage, deposits or discolourations on the machine.

- Never use aggressive detergents or scouring agents.
- Never use detergents that contain hydrochlorid acid or bleaches based on chlorine.
- Do not use cleaning utensils previously used to clean non-stainless steel.

9.1 Clean tray infeed station and dish clearing area

The most soiling occurs in the tray infeed station and dish clearing areas. It is therefore necessary to clean these areas daily.

A weak alkaline detergent is best suited for cleaning. The following are not suitable:

- Alcohol-based detergents
- Detergents containing chlorine
- Acidic detergents
- Cleaning additives that become sticky after drying
- Disinfectant

► The bi-cord conveyor is switched off and secured against being switched on again.

1. Remove coarse dirt in the tray infeed station and dish clearing areas.
 2. Empty and clean optional collection containers for leftovers, drinks and other waste.
 3. Clean sticky residues from sliding surfaces and round belts using a cloth and a weak alkaline detergent.
 4. Clean stainless steel surfaces using a soft cloth and a detergent suitable for stainless steel.
- ✓ The tray infeed station and crockery clearing areas have been cleaned.



Note

The remaining conveyor section between the tray infeed station and crockery clearing areas should be checked regularly for dirt and fallen items and cleaned if necessary.

9.2 Clean the return in the conveyor frame

The return in the conveyor frame becomes dirty, particularly in the tray infeed station area, and must be checked monthly for soiling and cleaned if necessary. A cloth can be used for cleaning.

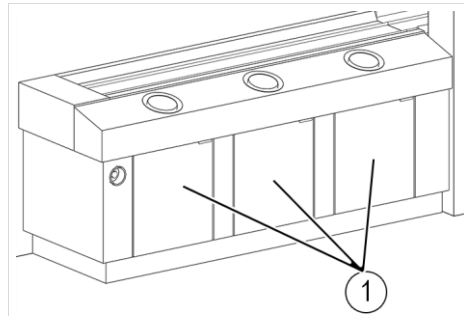

► The conveyor system is switched off and secured against being switched on again.

1. Open the panelling doors (1) of the tray infeed station.

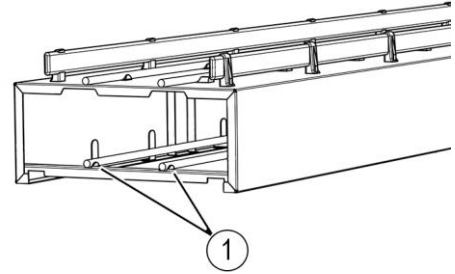

2. Check the guides of the round belt (1) in the conveyor frame for dirt and clean them. To do this, lift the round belt slightly off the guides.
 3. Check the further course and clean if necessary.
- ✓ The return in the conveyor frame is cleaned.

9.3 Clean cutlery lifting magnet

The cutlery lifting magnet must be cleaned daily. Only use soft cloths and slightly alkaline detergents for cleaning.

► The cutlery lifting magnet is switched off and secured against being switched on again.

1. Loosen the side nuts in the hood.
2. Fold the hood backward.
3. Clean the inside of the hood.
4. Clean the belt surface. To do this, move the belt on the carriers by hand.
5. Clean the frame and surfaces of the cutlery lifting magnet.
6. Close the hood and tighten the nuts.

✓ The cutlery lifting magnet is cleaned.

10 Maintenance



Note

Maintenance work may **only** be carried out by MEIKO authorised staff.

10.1 Maintenance plan

10.1.1 Abbreviations used

BFM	Cutlery lifting magnet
BSA	Fire screen

10.1.2 Maintenance intervals

Maintenance intervals in the maintenance table are specified as follows and refer to single-shift operation:

1D	Daily	6M	Every 6 months
1W	Weekly	1Y	Annually
1M	Monthly	3Y	Every 3 years

10.1.3 Maintenance work with the conveyor system switched off

Maintenance work with the conveyor system switched off	Interval	✓
BFM (optional): Check the belt and belt lock for damage.	1W	
Round belt: Check tension and adjust if necessary.	1M	
Check the round belt for mechanical damage.	1M	
Check the round belts for sticking, clean if necessary.	1M	
Clean the return in the conveyor frame.	1M	
Check the corner guide rollers.	6M	
Grease the drive chain.	6M	
Tray stacking trolley (optional): Clean the height limitation sensors.	6M	
BFM (optional): Check the conveyor frame for damage.	6M	
BFM (optional): Check the electrical cables for kinks and damage.	6M	
Check the safety signs on the conveyor system for legibility, replace if necessary.	1Y	
BFM (optional): Check the plate demagnetiser for damage.	1Y	

10.1.4 Maintenance work with the conveyor system switched on

Maintenance work with the conveyor system switched on	Interval	✓
Check all bearings for running noises and temperature.	6M	
Check the gear motors for noises and proper operation.	6M	
Check the drive and guide rollers forwards and backwards.	6M	
FSA (optional): Perform the function check.	1M	
FSA (optional): Maintenance by specialised company.	1Y	

11 Dismantling and disposal

In addition to valuable raw materials and recyclable materials, the packaging and the old appliance may also contain substances that are harmful to health and the environment and were required for the function and safety of the old appliance.

11.1 Dismantling and disposal of the old device



The appliance is marked with this symbol. Please observe the local regulations for proper disposal of your old appliance.

The components should be separated by material for recycling.

12 Index

A

Abbreviations	29
Ambient conditions	20
Assembly	21
Align machine feet	22
Assistance in case of malfunctions	26

B

Bypass restricted operation	25
-----------------------------------	----

C

Choose conveyor speed	23
Cleaning	27
Clean cutlery lifting magnet	29
Clean tray infeed station and dish clearing area	27

D

Declaration of conformity	5
Delivery contents	4
Designation of machine type	4
Dismantling	30
Dismantling and disposal	30
Disposal of packaging materials	21
Disposal of the old device	30

F

Fitting the conveyor body	22
Functional description	11

I

Intended use	6
--------------------	---

M

Maintenance	
Maintenance intervals	29
Maintenance plan	29
Maintenance work with the conveyor system switched off	30
Maintenance work with the conveyor system switched on	30

N

Notes on the operating instructions	4
illustrations	5

O

Operating modes	
Activate queue operation	23
Operating the folding conveyor table	24
Operation/use	23
Options	14

Alternative transport speed	17
Cutlery lifting magnet	15
Deactivation function	17
Folding conveyor table	14
Height limitation	15
Key switch for bypassing restricted operation	16
Queue operation	16
Sight screen and noise absorbing tunnel	18
Signal lamp	17
Transport stop button	17
Tray infeed	16
Tray merge	15
Tray position detection	18
Tray recognition	18

Overview display

Tray infeed station	12
---------------------------	----

Overview illustration

Clearing area	13
---------------------	----

P

Presentation conventions

Product description

Protective devices

Emergency off function	8
Emergency stop function	8
Fire screen	9

Protective equipotential bonding

R

Related documents

Requirements for the installation location

Requirements for the personnel

Requirements to the electrical connection

Resetting the emergency stop

Restricted operation

S

Safety

Safety devices

Safety information

Safety labels and signs

Switching off the system

Switching on

Switching tray recognition

T

Technical data

Technical limits

U

Unintended use

W

What to do in the event of an emergency10



The clean solution



MEIKO Maschinenbau GmbH & Co. KG

Englerstraße 3

77652 Offenburg

Germany

www.meiko-global.com

info@meiko-global.com